

ES3C40P

4.0 inch IPS ESP32-S3 Display Module User Manual



CONTENTS

1. Resource Description	3
2. Software Instructions	4
3. Hardware Instructions	4
3.1. Overview of module hardware resources is displayed	4
3.2. Detailed explanation of schematic diagram of display module	10
3.3. Precautions for display module use	20

1. Resource Description

The resource directory is shown in the following figure:

1-示例程序_Demo	2026/4/22 15:51	文件夹	
2-规格书_Specification	2026/4/22 17:39	文件夹	
3-尺寸图_Structure_Diagram	2026/4/22 15:51	文件夹	
4-数据手册_DataSheet	2026/4/22 17:40	文件夹	
5-原理图_Schematic	2026/4/22 15:51	文件夹	
6-用户手册_User_Manual	2026/4/22 17:45	文件夹	
7-工具软件_Tool_software	2026/4/22 15:51	文件夹	
8-快速使用_Quick_Start	2026/4/22 15:51	文件夹	
README(Important).txt	2025/7/1 15:12	文本文档	1 KB

Figure 1.1 Product Information Pack catalog

Directory	Content Description
1-示例程序_Demo	The sample program code, the third-party software library that the sample program relies on, the third-party software library replacement file, the software development environment setup instruction document, and the sample program instruction document.
2-规格书_Specification	Display module product specification, LCD screen specification and LCD display driver IC initialization code.
3-尺寸图_Structure_Diagram	Display module product size diagram, touch screen size diagram, and product 3D diagram
4-数据手册_DataSheet	LCD display driver ST7796S data manual, capacitive touch screen driver FT6336U data manual, ESP32-S3 main control data manual and hardware design guidance document, audio amplifier chip FM8002E data manual, 5V to 3.3V voltage regulator data manual, battery charging management chip TP4054 data manual, audio codec chip ES8311 data manual, downward silicon microphone data manual, and built-in chip RGB three color light data manual.
5-原理图_Schematic	Product hardware schematic, ESP32-S3 module IO resource allocation table, schematic, and PCB component packaging
6-用户手册_User_Manual	Product user documentation
7-工具软件_Tool_software	WIFI and Bluetooth test APP and debugging tools, USB to serial port driver, ESP32 Flash download tool software, character take-up software, image take-up software, JPG image processing software and serial port debugging tools.
8-快速使用_Quick_Start	Need to burn bin file, flash download tool and use instructions.

2. Software Instructions

Display module software development steps are as follows:

- A. Build ESP32 platform software development environment;
- B. if necessary, import third-party software libraries as a basis for development;
- C. open the software project to be debugged, you can also create a new software project;
- D. power on the display module, compile and download the debugging program, and then check the software running effect;
- E. the software effect does not reach the expected, continue to modify the program code, and then compile and download, until the effect reaches the expected;

For details about the preceding steps, see the documentation in the 1-Demo directory.

3. Hardware Instructions

3.1. Overview of module hardware resources is displayed

Module hardware resources are shown in the following two figures:



Figure 3.1 Module hardware resources 1

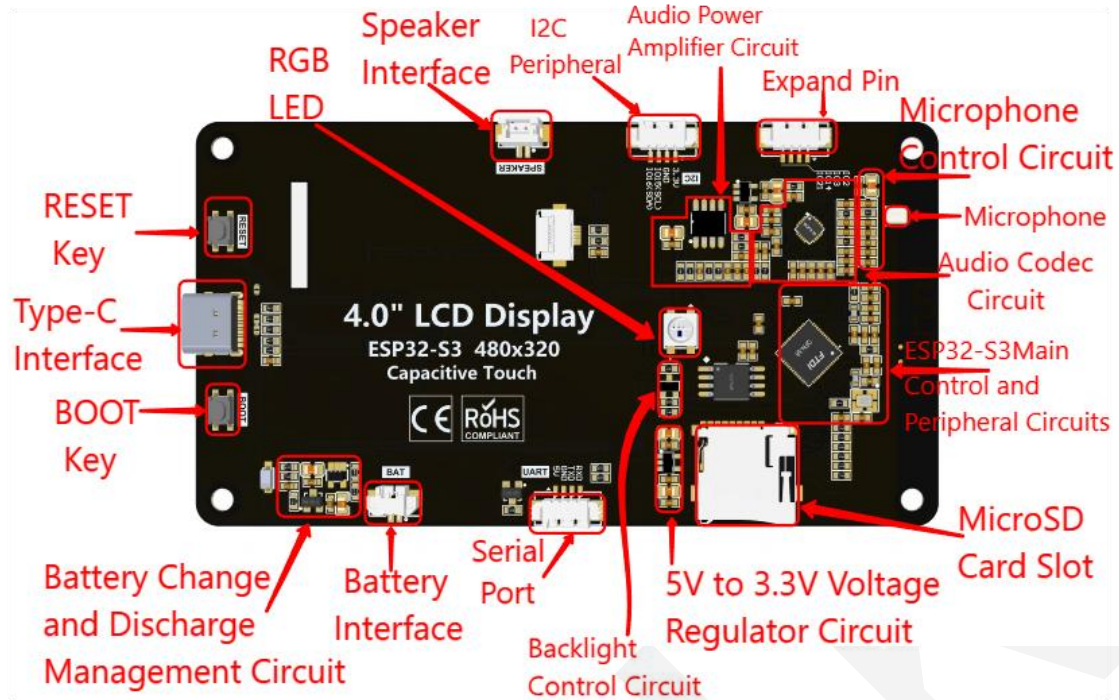

Figure 3.2 Module hardware resources 2

The hardware resources are described as follows:

1) LCD

The LCD screen is an IPS display screen with a size of 4.0 inches, a driver IC of ST7796S, and a resolution of 480x320. Connect to ESP32-S3 using a 4-wire SPI communication interface.

A. Introduction to ILI9341 controller

The ST7796S controller supports a maximum resolution of 480 * 320 and has a GRAM size of 172800 bytes. Simultaneously supports 8-bit, 9-bit, 16 bit, and 18 bit parallel data buses, as well as 3-wire and 4-wire SPI serial ports. Due to the large number of IO ports required for parallel control, SPI serial port control is still the most commonly used. ST7796S also supports 65K and 262K RGB color display, with rich display colors. It also supports rotation display, scrolling display, and video playback, with various display modes.

The ST7796S controller uses 16 bits (RGB565) to control the display of a pixel, so each pixel can display up to 65K colors. The pixel address is set in the order of rows and columns, and the increasing and decreasing directions are determined by the scanning method. The ST7796S display method is to set the

address first and then the color value.

B. Introduction to SPI communication protocol

The writing mode timing of the 4-wire SPI bus is shown in the following figure:

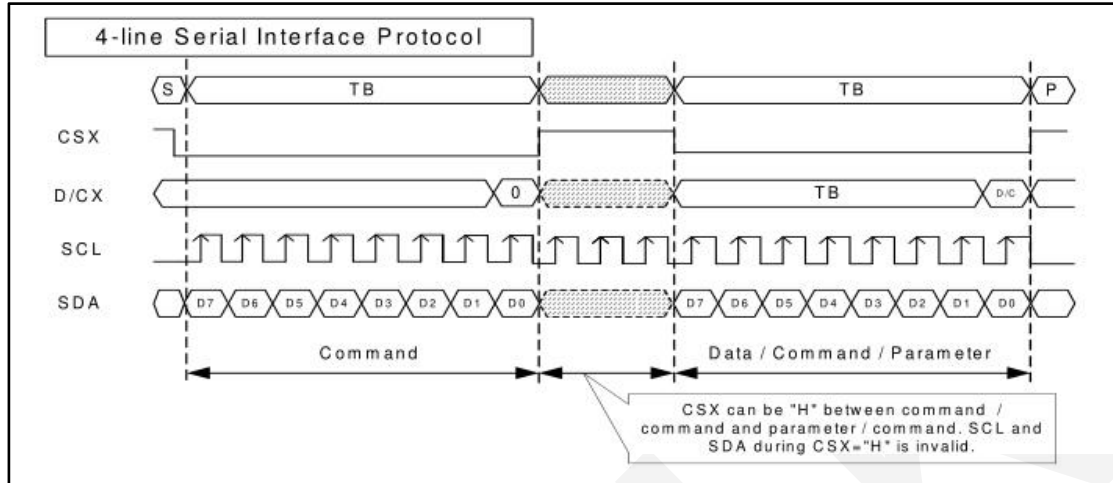

Figure 3.3 Writing mode timing of 4-wire SPI bus

CSX is a slave chip selection, and the chip will only be enabled when CSX is at low power level.

D/CX is the data/command control pin of the chip. When DCX is writing commands at low levels, data is written at high levels

SCL is the SPI bus clock, with each rising edge transmitting 1 bit of data;

SDA is the data transmitted by SPI, which transmits 8 bits of data at once. The data format is shown in the following figure:

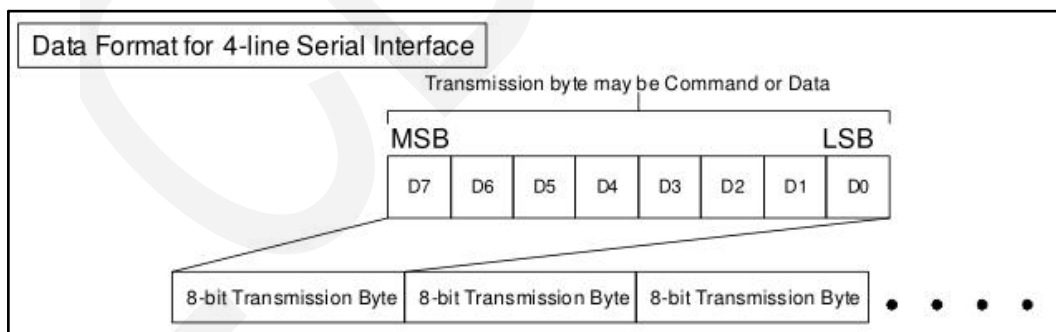

Figure 3.4 4 SPI transmission data format

High bit first, transmit first.

For SPI communication, data has a transmission timing, with a combination of real-time clock phase (CPHA) and clock polarity (CPOL):

The level of CPOL determines the idle state level of the serial synchronous clock,

with CPOL=0, indicating a low level. CPOL pair transmission protocol

The discussion did not have much influence;

The height of CPHA determines whether the serial synchronous clock collects data on the first or second clock jump edge,

When CPHL=0, perform data collection at the first transition edge;

The combination of these two forms four SPI communication methods, and SPI0 is commonly used in China, where CPHL=0 and CPOL=0

2) Capacitive Touch Screen

The capacitive touch screen has a size of 4.0 inches and is connected to the FT6336U control IC through four pins: CTP_RST, CTP_INT, CTP_SDA, CTP_SCL.

3) ESP32-S3 Main Control and Peripheral Circuits

ESP32-S3 is equipped with an Xtensa dual core 32-bit LX7 dual core microprocessor, supporting clock speeds up to 240MHz. Internally equipped with 348KB ROM, 512KB SRAM, 16KB RTC SRAM, 8MB OPI PSRAM, and external 16MB QSPI Flash. Supports 2.4GHz WIFI, Bluetooth V5.0, and low-power Bluetooth module. 45 external GPIO ports, supporting SD cards UART、SPI、SDIO、I2C、LED PWM、 Motor PWM, I2S, IR, pulse counter GPIO、 Capacitive touch sensors, ADC, DAC, TWAI, LCD, USB and other peripheral interfaces. The peripheral circuit includes power filtering circuit, external Flash circuit, PCB board mounted antenna circuit, crystal oscillator circuit, etc.

4) MicroSD Card Slot

Using SDIO communication method and ESP32-S3 connection, supporting MicroSD cards of various capacities.

5) RGB LED

Use RGB tri color lights with internal IC. Only one GPIO is needed to input different timing waveforms to control the color and frequency of the light.

6) Serial Port

An external serial port module is used for serial port communication.

7) Battery Interface

Two-pin interface, one for the positive electrode, one for the negative electrode,

access the battery power supply and charging.

8) Battery Charge and Discharge Management Circuit

The core device is TP4054, this circuit can control the battery charging current, the battery is safely charged to saturation state, but also can safely control the battery discharge.

9) BOOT Key

After the display module is powered on, pressing will lower IO0. If the moment the module is powered on or the ESP32-S3 is reset, lowering IO0 will enter the download mode. Other cases can be used as ordinary buttons.

10) Type-C Interface

The main power supply interface and program download interface of the display module. Connect the internal USB interface of ESP32-S3, which can simulate a USB serial port for downloading and serial communication, and can also provide power.

11) 5V to 3.3V Voltage Regulator Circuit

It includes two circuits: an audio 5V to 3.3V circuit and a non audio 5V to 3.3V circuit. The audio 5V to 3.3V circuit is specifically designed to power audio related circuits, while the non audio 5V to 3.3V circuit is specifically designed to power circuits outside of audio. The core component of the circuit is the ME6217C33M5G LDO voltage regulator. This voltage regulator circuit supports a wide voltage input of 2V~6.5V and a stable voltage output of 3.3V. The maximum output current is 800mA, which can fully meet the voltage and current requirements of the display module.

12) RESET Key

After the display module is powered on, pressing will pull the ESP32-S3 reset pin down (the default state is pull up), so as to achieve the reset function.

13) Expand Pin

The ESP32-S3 chip does not use four IO ports. Bring it out for use by external devices.

14) Backlight Control Circuit

The core device is BSS138 field effect tube. One end of this circuit is connected to the backlight control pin on the ESP32 master, and the other end is connected to the negative pole of the LCD screen backlight LED lamp. Backlight control pin pull up, back light, otherwise off.

15) Speaker Interface

Wiring terminals must be connected vertically. Used to access mono speakers and loudspeakers.

16) Audio Power Amplifier Circuit

The core device is the FM8002E audio amplifier IC. One end of this circuit is connected to the ESP32 audio DAC value output pin and the other end is connected to the horn interface. The function of this circuit is to drive a small power horn or speaker to sound. For 5V power supply, the maximum drive power is 1.5W (load 8 ohms) or 2W (load 4 ohms).

17) I2C Peripheral Interface

4-wire horizontal interface. Lead out the I2C0 bus of ESP32-S3 for external I2C devices, and share it with capacitive touch and audio codec IC. If touch and audio functions are not needed, it can also be used as a regular IO port.

18) Audio Codec Circuit

The core component is the ES8311 audio codec IC. It is configured and initialized through the I2C bus (shared with the capacitive touch screen), and then transmits audio data through the I2S bus and ESP32-S3. In addition, ES8311 is also connected to MIC input audio, and then connected to an amplifier circuit to play audio.

19) Microphone control circuit

Used to power the microphone and filter the signal, and then transmit it to the audio codec circuit.

20) Microphone

Downward MEMS silicon microphone, responsible for audio input, converts sound signals into electrical signals.

3.2. Detailed explanation of schematic diagram of display module

1) Type-C interface circuit

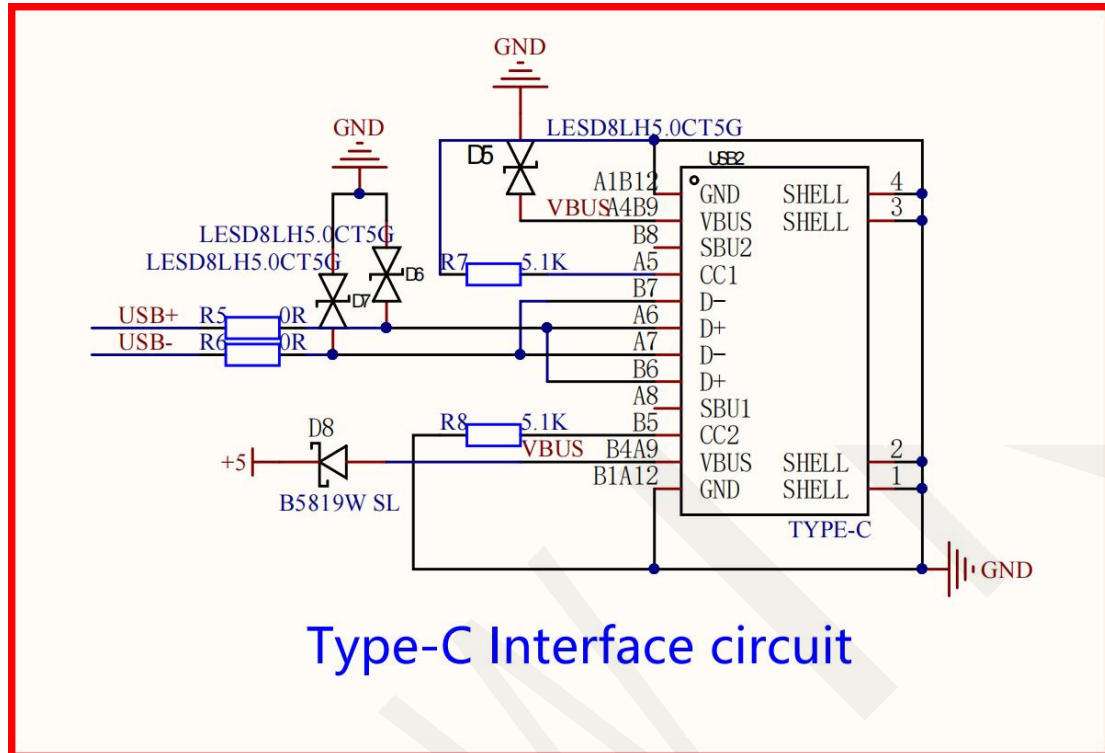

Figure 3.5 Type-C interface circuit

In this circuit, D8 is a Schottky diode used to prevent current reversal. D5~D7 are static surge protection diodes to prevent damage to the display module due to excessive voltage or short circuit. R7 and R8 are pull-down resistors. USB2 is a Type-C female socket. The display module is connected to Type-C power supply, program download, and serial communication through USB2. Among them, +5V and GND are positive voltage and ground signals of the power supply, while USB-D- and USB-D+ are USB differential signals, which are transmitted to the onboard USB to serial port circuit.

2) 5V to 3.3V voltage regulator circuit

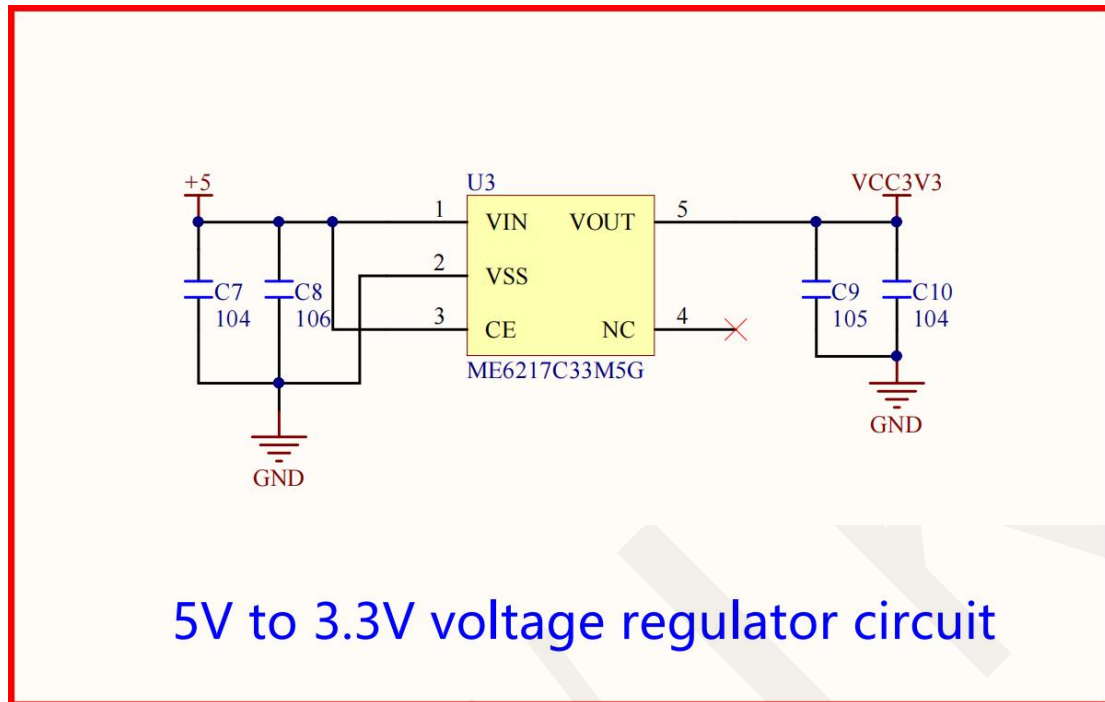

Figure 3.6 Voltage regulator circuit

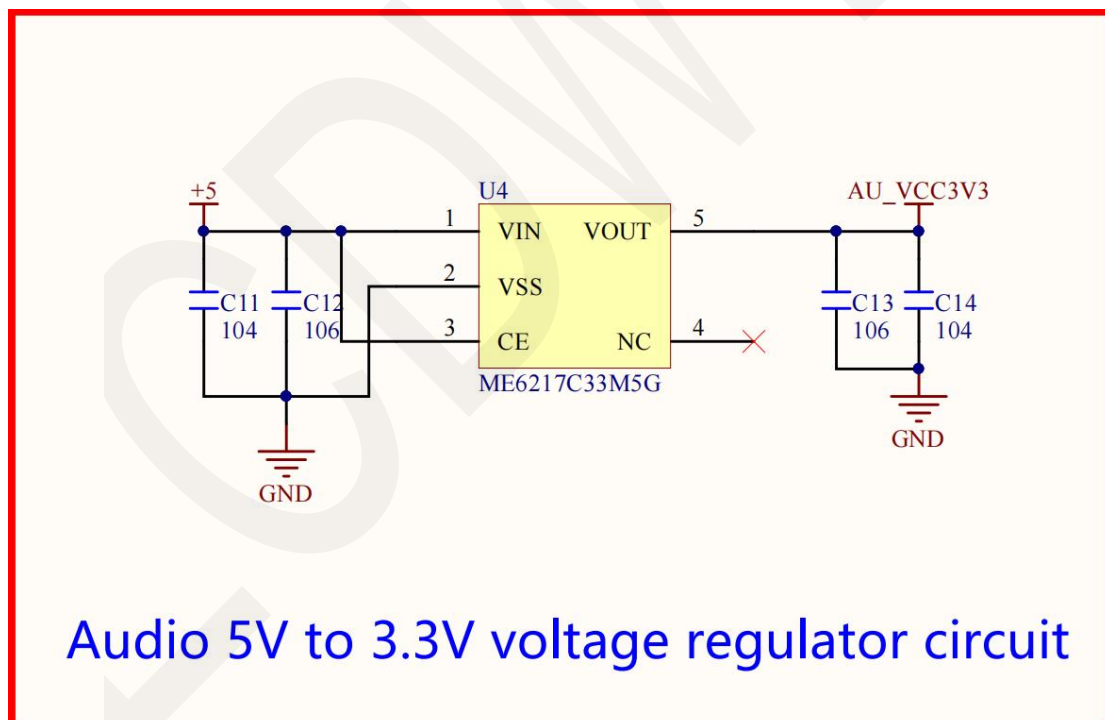

Figure 3.7 Audio Voltage regulator circuit

In this circuit, C7~C14 are bypass filtering capacitors used to maintain stable input and output voltages. U3 and U4 are 5V to 3.3V LDOs, with the model

ME6217C33M5G. Because most of the circuits on the display module require 3.3V power supply, and the power supply for Type-C interface input is basically 5V, a voltage stabilization conversion circuit is needed. The audio 5V to 3.3V voltage regulator circuit supplies power to the audio circuit. The 5V to 3.3V voltage regulator circuit is a power supply for circuits other than audio circuits.

3) Capacitive touch screen interface circuit

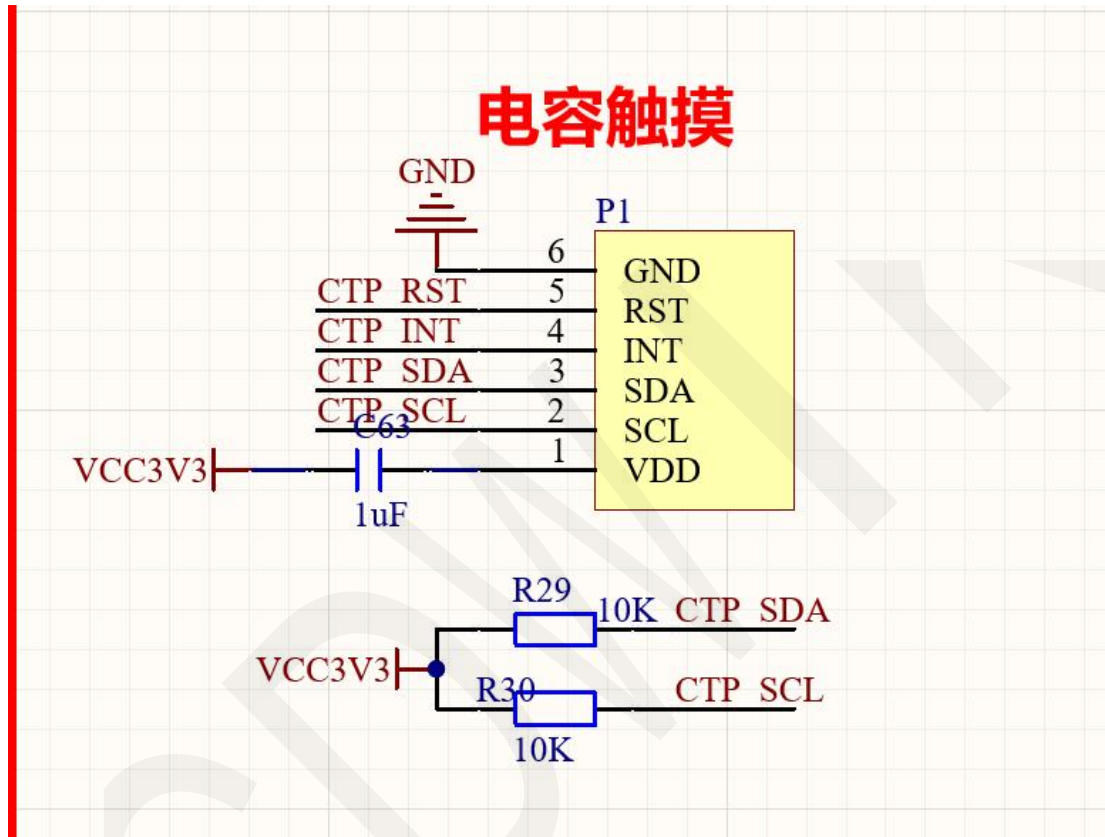

Figure 3.8 Capacitive touch screen interface circuit

In this circuit, P1 is a 0.5mm spacing bottom contact flip FPC socket used to connect capacitive touch screens. It communicates with the ESP32-S3 master through the I2C bus, and the I2C slave device address is 0x38. **CTP_RST** is the reset signal for the touch screen, and **CPT_INT** is the interrupt signal for the touch screen. R29 and R30 are pull-up resistors for the I2C bus.

4) Audio power amplifier circuit

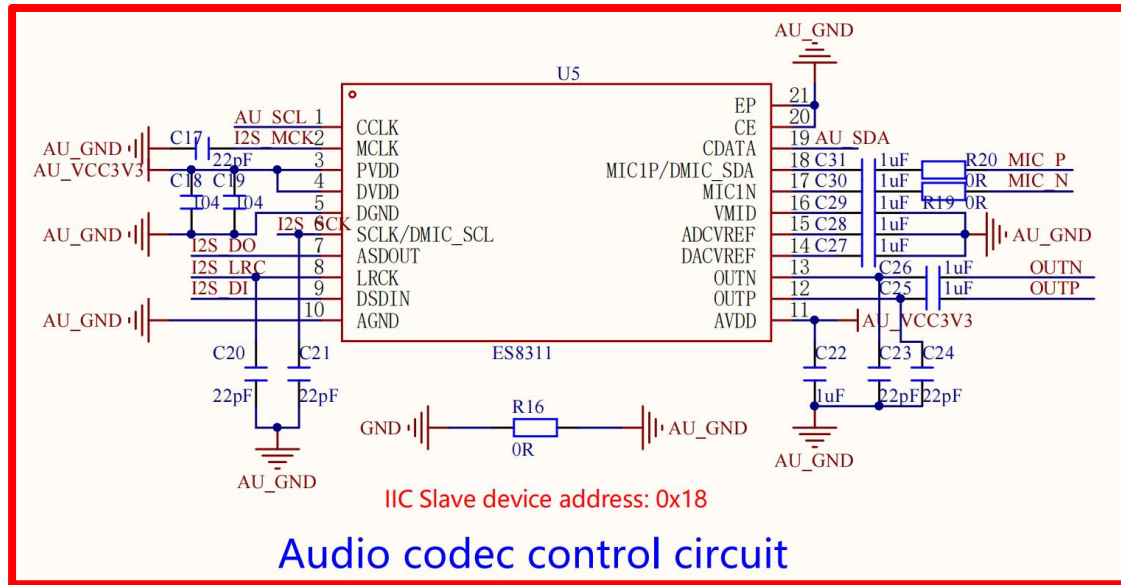

Figure 3.9 Audio power amplifier circuit

In this circuit, R21, R22, C42, C43, C46, and C47 form an RC filtering circuit, and R24, R25, and R28 are gain adjustment resistors for operational amplifiers. The audio output is in differential output mode. When the resistance of R28 remains unchanged, reducing the resistance of R24 and R25 will increase the volume of the external speaker. C41, C48, and C49 are input coupling capacitors. C44 and C45 are filtering capacitors, and R26 is a pull-up resistor. R27 is a 0R resistor used to connect the analog ground and conventional ground of the audio power amplifier circuit. JP3 is the speaker/speaker interface. U6 is the FM8002E audio amplifier IC. The audio differential signals OUTP and OUTN are input to the FM8002E gain amplifier through the encoding and decoding circuit, and then output to the speaker/speaker through the VO1 and VO2 pins. SHUTDOWN is the FM8002E enable pin, which is enabled at low level and defaults to high level.

5) ESP32-S3 main control circuit

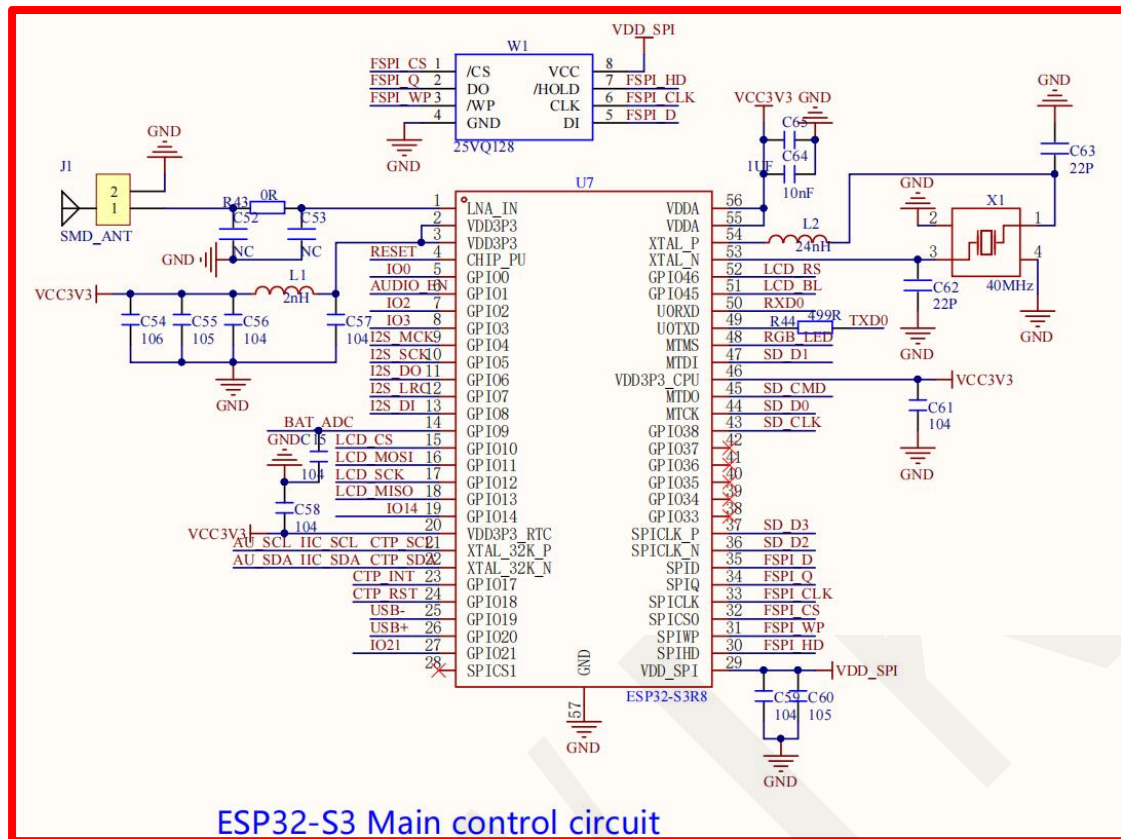

Figure 3.10 ESP32-S3 main control circuit

In this circuit, U7 is the main control chip of ESP32-S3R8, where R8 represents the chip with 8MB oct psram inside. J1, C52, C53, R43 together form the PCB onboard antenna circuit. C54~C57 and L1 together constitute the CLC filtering circuit of the ESP32-S3 chip analog power supply. C5, C58~C61, C64, C65 are all power filter capacitors. C62, C63, and X1 together form a passive crystal oscillator circuit. R44 is the impedance balancing resistor for the serial TX signal. W1 is a 16MB QPI FLASH. For a detailed introduction of the circuit, please refer to the official documentation.

6) Key reset circuit

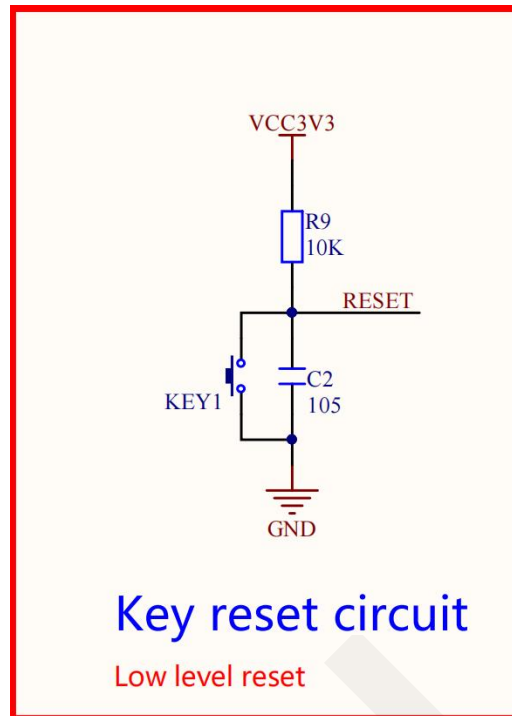

Figure 3.11 Key reset circuit

In this circuit, KEY1 is the button, R9 is the pull-up resistor, and C2 is the delay capacitor. Reset principle:

- A. After power on, C2 charges, which is equivalent to a short circuit. The RESET pin is grounded, and ESP32-S3 enters the reset mode Status;
- B. C2 charging is complete, at this point C2 is equivalent to an open circuit, the RESET pin is pulled high, and the ESP32-S3 reset ends, Enter normal working state;
- C. Press KEY1, the RESET pin is grounded, ESP32-S3 enters the reset state, and C2 discharges through KEY1;
- D. Release KEY1 and charge C2. At this point, C2 is equivalent to a short circuit, the RESET pin is grounded, and ESP32-S3 is still in operation Reset state, wait for C2 to finish charging, the RESET pin is pulled high, ESP32-S3 reset ends, and enters positive state Constant working state;

If the reset is unsuccessful, the capacitance of C2 can be appropriately increased to delay the low level time of the RESET pin.

7) Interface circuit of serial module

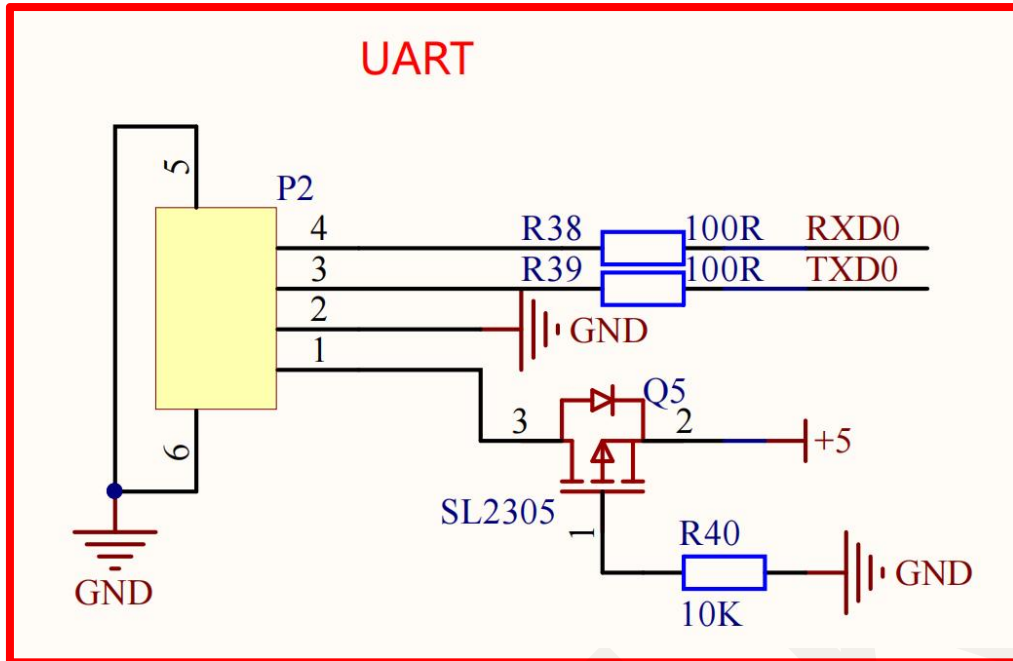

Figure 3.12 Interface circuit of serial module

In this circuit, P2 is a 4P 1.25mm spacing mount, R38 and R39 are impedance balancing resistors, and Q5 is a field-effect transistor that controls the 5V input power supply. R40 is a pull-down resistor. RXD0 and TXD0 are connected to the serial port pins, while the other two pins are powered. Q5 and R40 can form an anti reverse circuit.

8) Expand IO and peripheral interface circuits

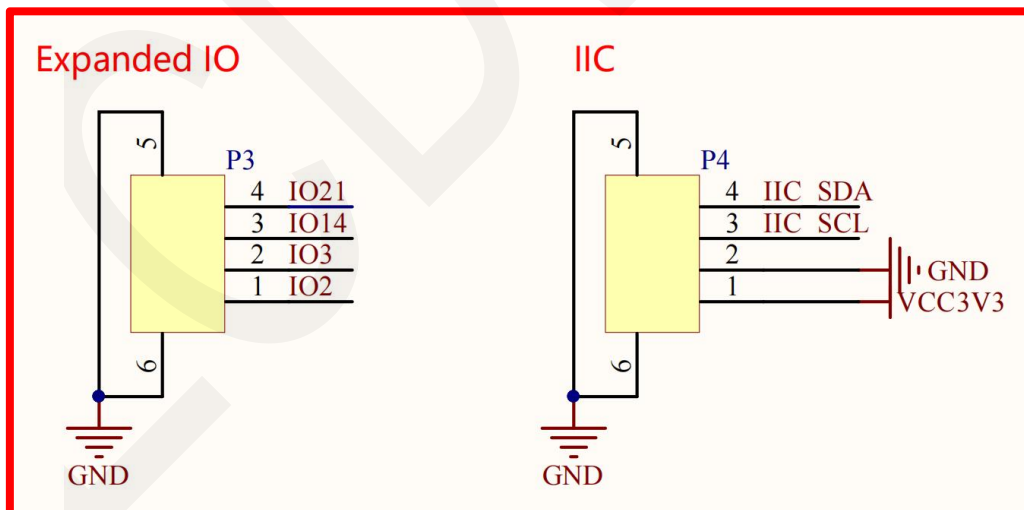

Figure 3.13 Extended IO and peripheral interface circuits

In this circuit, P3 and P4 are 4P mounts with a spacing of 1.25mm. IO2, IO3, IO14, and IO21 are four idle IO ports that can be connected to peripherals or used

as SPI interfaces. IIC_SDA and IIC_SCL are external I2C interfaces that can be connected to I2C devices. Please note that IIC_SDA and IIC_SCL cannot be used for regular IO.

9) Battery charge and discharge management circuit

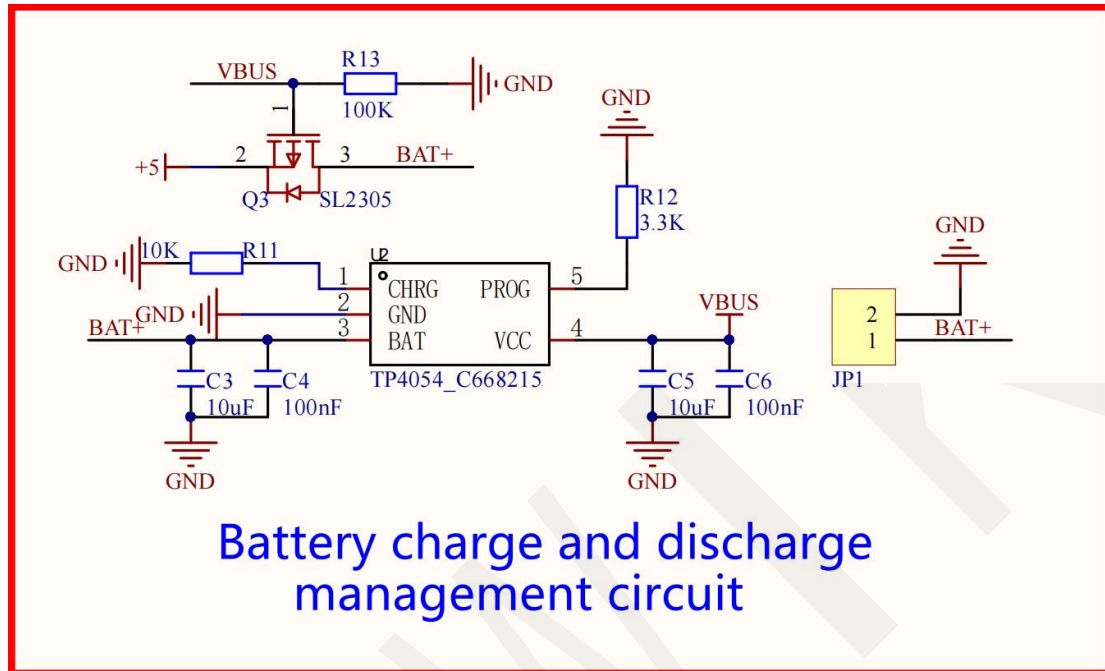

Figure 3.14 Battery charge and discharge management circuit

In this circuit, C3~C6 are bypass filter capacitors. U2 is the TP4054 battery charging management IC. R12 is the battery charging current regulating resistor. JP1 is a 2P 1.25mm spacing mount, connected to a battery. Q3 is a P-channel field-effect transistor. R13 is the Q3 gate pull-down resistor. TP4054 charges the battery through the BAT pin. The smaller the resistance of R12, the higher the charging current, with a maximum of 500mA. Q3 and R13 together form the battery discharge circuit. When not powered through the Type-C interface, the +5V voltage is 0. At this time, the Q3 gate is pulled down to a low level, and the drain and source are conductive. The battery supplies power to the entire display module. When powered through the Type-C interface, the +5V voltage is 5V. At this time, the Q3 gate is at a high level of 5V, the drain and source are cut off, and the battery power supply is interrupted.

10) 18P LCD panel wire welding interface

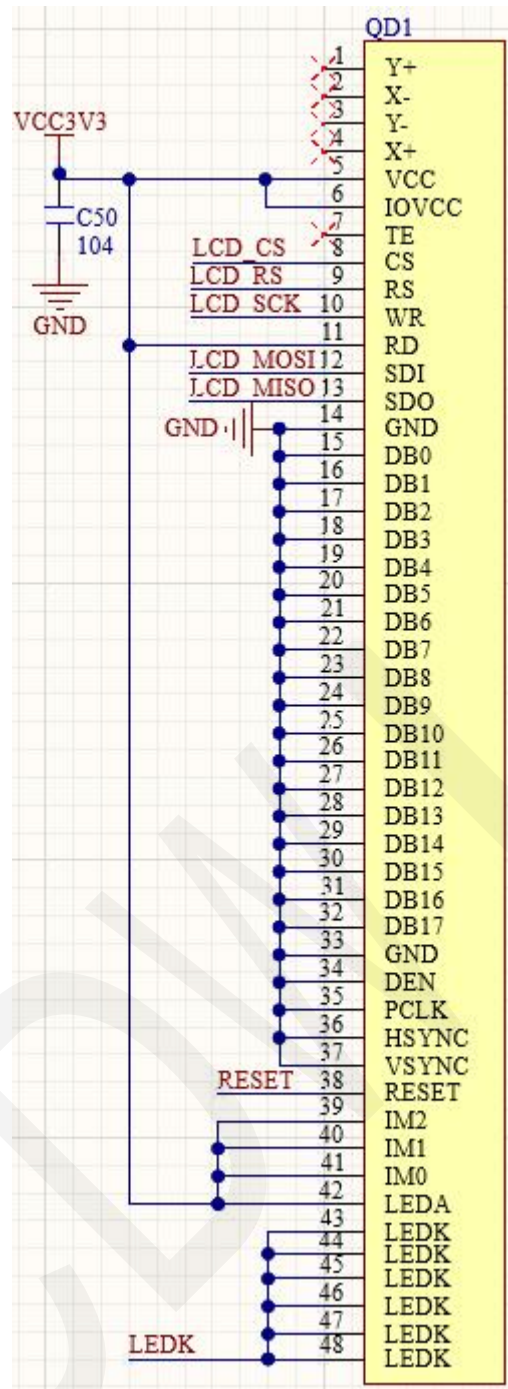

Figure 3.15 18P LCD panel wiring welding interface

In this circuit, C50 is a bypass filter capacitor, and QD1 is an 48P 0.8mm pitch LCD screen soldering interface. QD1 has resistance touch screen signal pins, LCD screen voltage pins, SPI communication pins, control pins, and backlight circuit pins. ESP32-S3 controls the LCD screen and touch screen through these pins.

11) Download key circuit

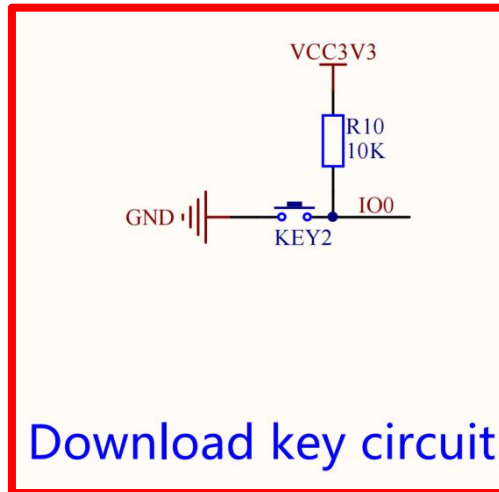

Figure 3.16 Download button circuit

In this circuit, KEY2 is the button and R10 is the pull-up resistor. The default state of IO0 is high level, and when KEY2 is pressed, it is low level. Press and hold KEY2, power on or reset, ESP32 will enter download mode. In other cases, KEY2 can be used as a regular button.

12) Battery power detection circuit

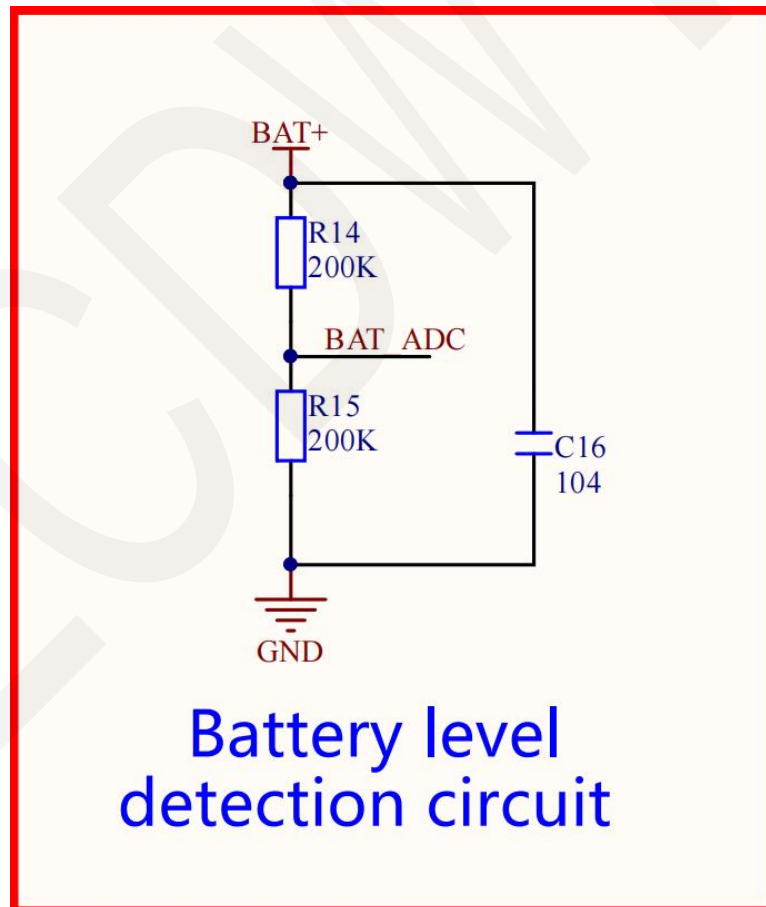

Figure 3.17 Battery level detection circuit

resistor. BAT_SDC is the voltage value at both ends of R15, which is transmitted to the ESP32-S3 controller through IO pins with ADC input function, and then converted by ADC to obtain the battery voltage value. The reason for using a voltage divider resistor is that the maximum value converted by the ESP32-S3 ADC is 3.3V, while the battery saturation voltage is 4.2V, which is beyond the range. The actual battery voltage value is obtained by multiplying the obtained voltage value by 2.

13) LCD backlight control circuit

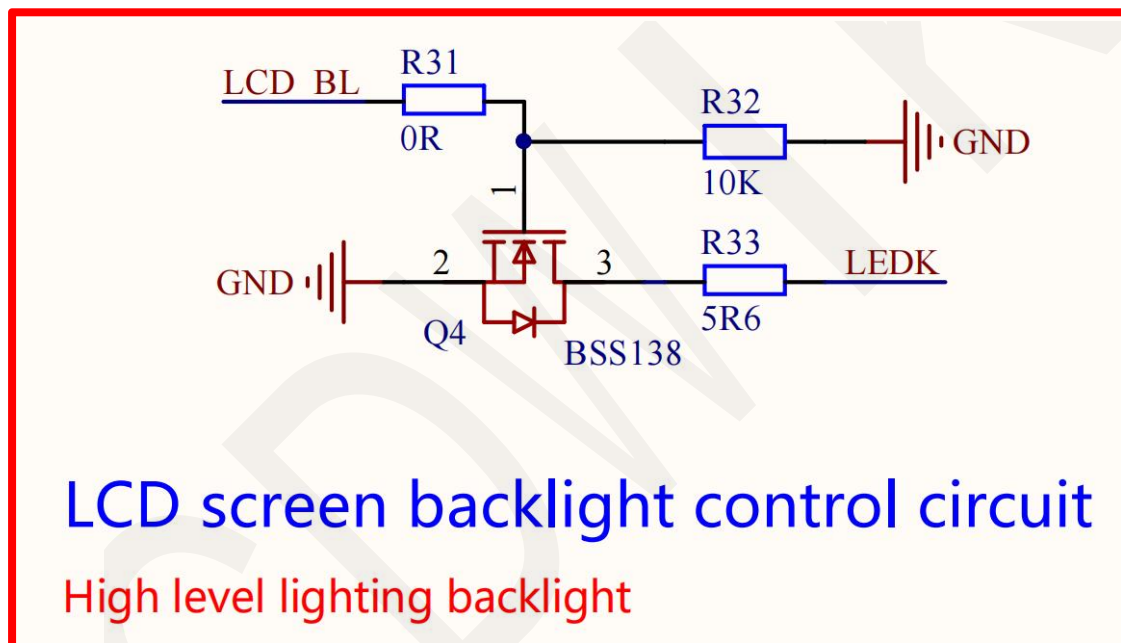

Figure 3.16 LCD backlight control circuit

In this circuit, R31 is a debugging resistor and is temporarily reserved. Q4 is an N-channel field-effect transistor, R32 is a Q4 gate pull-down resistor, and R33 is a backlight current limiting resistor. The LCD backlight LED lights are in parallel, with the positive pole connected to 3.3V and the negative pole connected to the drain of Q4. When the control pin LCD_BL outputs a high level, the drain and source of Q4 are conductive, and the negative pole of the LCD backlight is grounded, causing the backlight LED lights to turn on and emit light; When the control pin LCD_BL outputs a low level, the drain and source of Q4 are cut off, and the negative terminal of the

LCD screen backlight is suspended, causing the backlight LED to not conduct. The LCD screen backlight is not on by default. Reducing the resistance of R33 can increase the maximum brightness of the backlight. In addition, the LCD_BL pin can input PWM signals to adjust the brightness of the LCD screen backlight.

14) RGB three-color light control circuit

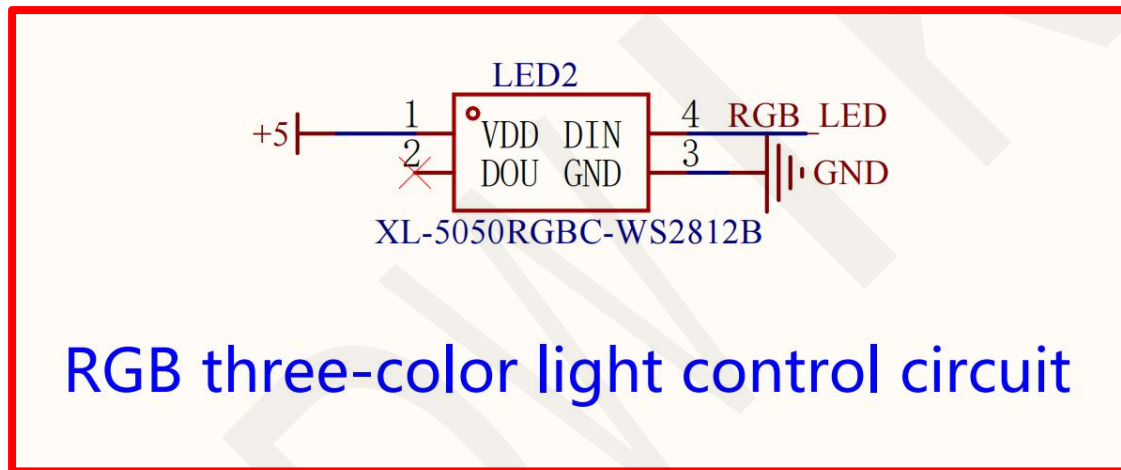
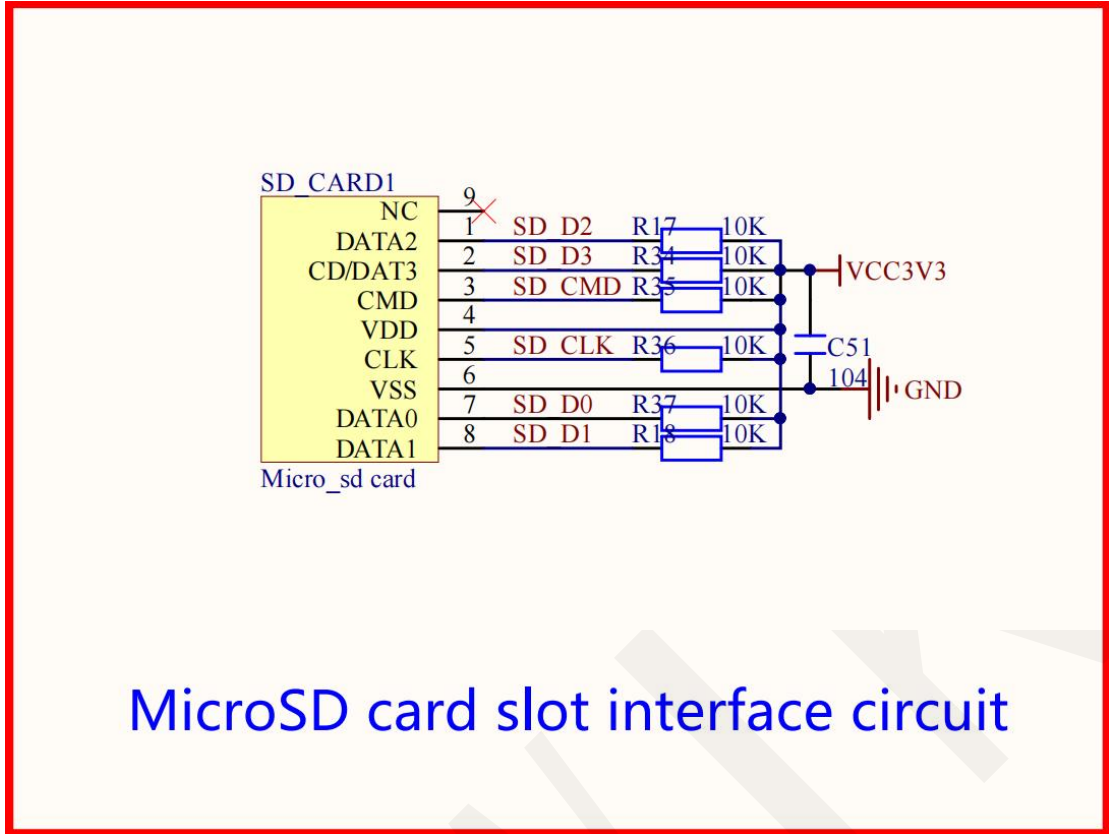

Figure 3.19 LCD backlight control circuit

In this circuit, LED2 is an RGB three color light with an internal control IC. It uses 5V power supply and only requires one IO port control, which saves IO resources. The principle is to drive different colored lights to emit light by inputting different timing waveforms through RGB-LED signals.

15) MicroSD card slot interface circuit



MicroSD card slot interface circuit

Figure 3.20 MicroSD card slot interface circuit

In this circuit, SD_CRD1 is the MicroSD card slot. R17, R8, R34~R37 are pull-up resistors for each pin. C51 is a bypass filter capacitor. This interface circuit adopts SDIO communication method, which is faster than SPI communication speed. Supports high-speed storage of MicroSD cards.

16) Audio decoding control circuit

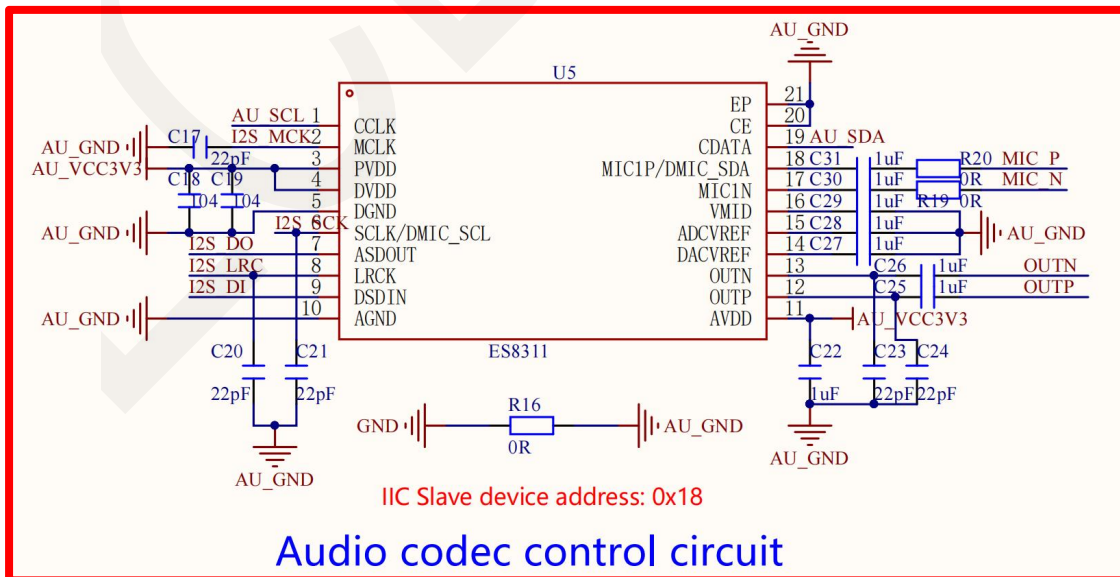

Audio codec control circuit

Figure 3.21 Audio codec control circuit

In this circuit, C17~C24 are bypass capacitors, while C25~C31 are filter capacitors. U5 is the ES8311 audio codec IC. R19 and R20 are impedance balancing resistors. R16 is a 0R resistor used to connect the analog ground and conventional ground of the audio codec circuit. ES8311 is initialized and configured through I2C and ESP32-S3 main control communication, with the slave device address being 0x18. Audio data is transmitted through the I2S bus. It converts and encodes the audio signal input by the MIC through ADC, and sends it to the ESP32-S3 controller. After processing, the controller sends it to ES8311, which then converts and decodes it through DAC before outputting it through the speaker.

17) MIC control circuit

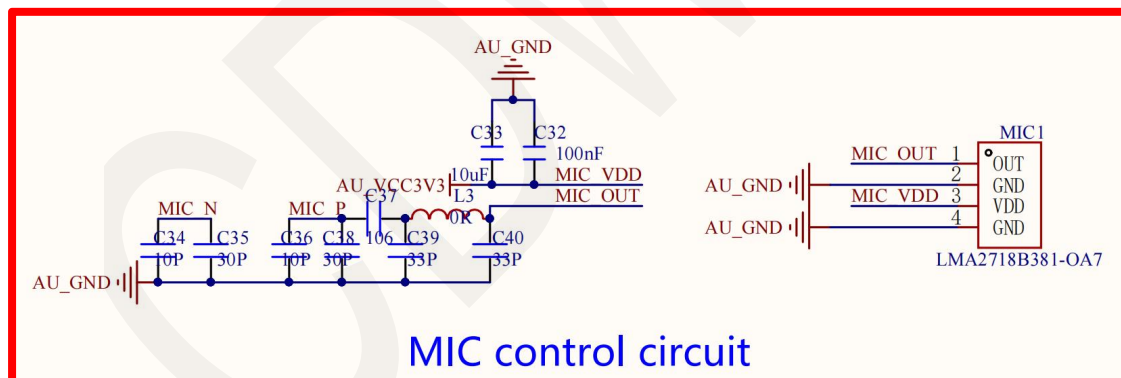

Figure 3.22 MIC control circuit

In this circuit, C32~C36 and C38 are all bypass capacitors. C37 is a filtering capacitor. C39, C40, and L3 together form the CLC filtering circuit. MIC1 is a bottom in MEMS silicon microphone. Input sound through MIC, filter it and transmit it to the audio codec circuit.

3.3. Precautions for display module use

- 1) The display module is charged with the battery, the external speaker plays the audio, and the display screen is also working, at this time the total current may exceed 500mA. In this case, you need to pay attention to the maximum current supported by the Type-C cable and the maximum current supported by the power supply interface to avoid insufficient power supply.
- 2) During use, do not touch the LDO voltage regulator and battery charge management IC with your hands to avoid being burned by high temperature.
- 3) When connecting the IO port, pay attention to the IO usage to avoid misconnecting and the program code definition does not match.
- 4) Use the product safely and reasonably.