



液晶显示模组规格书

LCD MODULE SPECIFICATION

MODEL NO (模组型号):

QYS181401

客户名称:			深圳市千一显示科技有限公司		
拟制 DESIGNED	审核 CHECKED	批准 APPROVED	拟制 DESIGNED	审核 CHECKED	批准 APPROVED
			周立国		



ISO9001:2008 版
质量体系认证



0 6 3

地址: 深圳市宝安区福永镇兴业一路华伦科技园 16 栋 3 楼

Address: Floor 3 Building 16, Chengdexuan Hualun Science. Park,
Xingye 1st Road, Bao'an District, Shenzhen City

web: <http://www.qytft.com>

Tech-Email: qyxskj@126.com



修改记录 Records of Revision

日期 DATE	版本 VERSION	修改摘要 SUMMARY	拟制 DESIGNED	备注 REMARK
2020.03.10	00	初版发行	ZHOULIGUO	



目录 Contents

1. 产品特征 Product Features-----	4
2. 物理规格 Physical Specifications -----	4
3. 产品图纸 Product Drawings -----	5
4. 接口定义 The Interface Definition-----	6
5. 极限参数 Absolute Maximum Ratings -----	7
6. 电气参数 Electrical Characteristics -----	7
7. 光学参数 Optical Characteristics -----	8
8. 时序特性 Timing Characteristics -----	10
9. 初始化建议 Initial code Suggestion -----	11
10. 品质检验标准 LCM Quality Criteria -----	13
10.1 外观及功能检验标准 Visual & Function Inspection Standard-----	13
10.1.1 检验条件 Inspection conditions-----	13
10.1.2 定义 Definition-----	13
10.1.3 抽样计划 Sampling Plan-----	14
10.1.4 目测检验标准 Criteria (Visual)-----	15
10.1.5 功能性标准 Criteria (functional items)-----	17
10.2 可靠性实验 Reliability Test-----	18
10.3 安全说明 Safety instructions-----	19
10.4 模组使用注意事项 Handling Precautions-----	19
10.5 使用说明 Operation instructions-----	19
10.6 存储方法 Storage instructions-----	20
10.7 保修期限 Limited Warranty-----	20
11. 包装方法 Packing method-----	21



1. 产品特征 Product Features

项目 (Item)	描述(Description)
(1) 显示类型 (Display Type)	1.77 inch TFT Normally white
(2) 分辨率 (Resolution)	128*RGB*160
(3) 显示色彩 (color)	65K/262K
(4) 视角 (View Angle)	12 O'CLOCK
(5) 驱动IC (Driver IC)	ST7735S
(6) 接口类型 (Interface Types)	SPI_4-line 8bit
(7) 背光模式 (Backlight)	并联 2 颗灯(2 LED Parallel)
(8) 触摸屏 (Touch Panel)	无 (Nothing)

2. 物理规格 Physical Specifications

项目 (Item)	规格 (Specification)	单位 (Units)
(1) 外形尺寸(Outline Dimension)	34.70*46.70*2.40±0.10	mm
(2) 显示区尺寸(Active Area Dimension)	28.03*35.04	mm
(3) 解析度(Resolution Dimension)	128*3RGB*160	/
(4) 像素点尺寸(Pixel Pitch Dimension)	0.073*0.219	mm
(5) 结构类型(Structure Type)	COG+FPC+BL (note)	/

Note: COG: Chip On Glass (LCD+IC); BL: Backlight; TP: Touch Panel

3. 产品图纸 Product Drawings

(见下页)

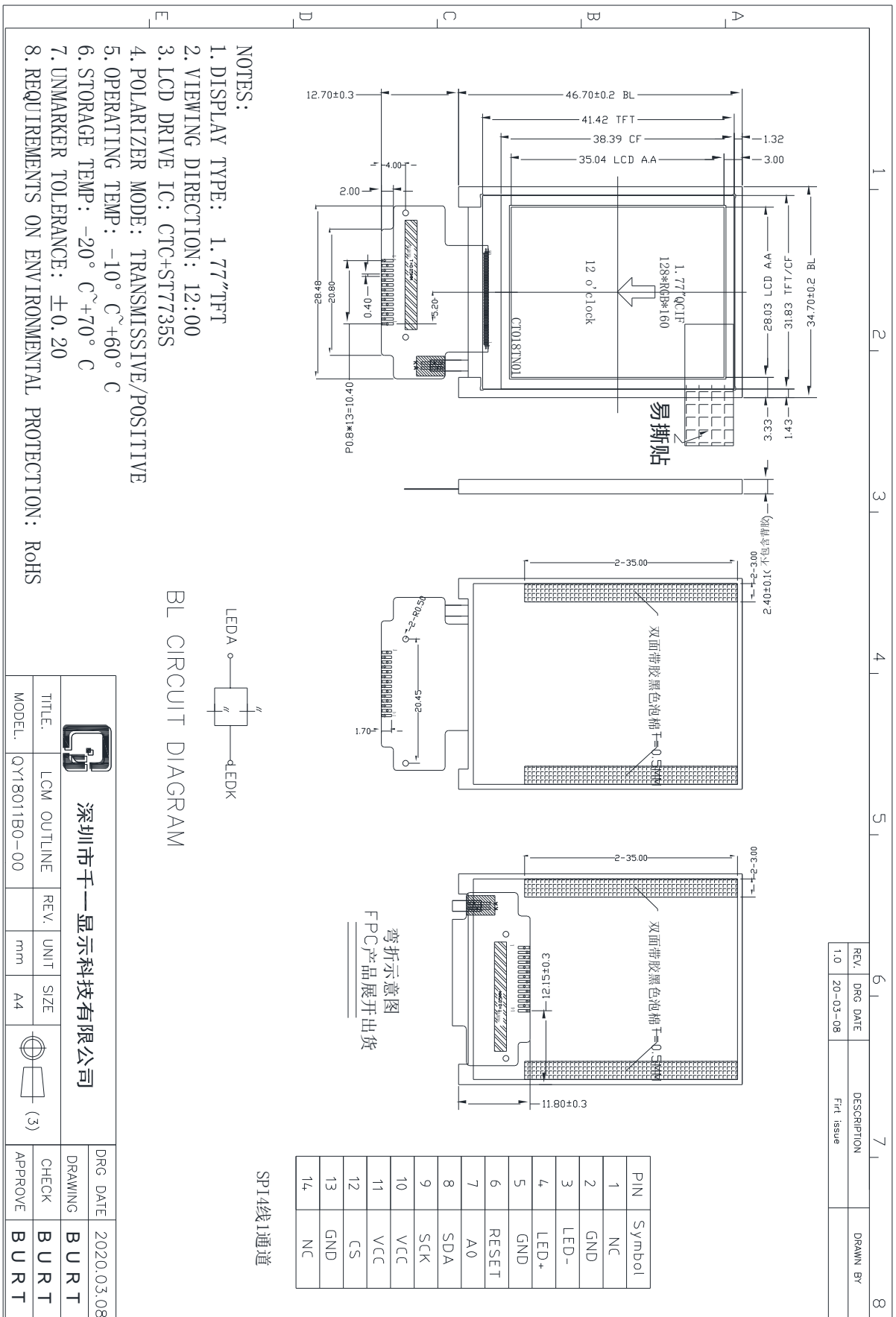



4. 接口定义 The Interface Definition

编号(PIN NO.)	符号(SYMBOL)	描述(Description)	输入/输出(I/O)
1	NC	Not connected	
2	GND	Power Ground	Power supply
3	LEDK	Cathode pin OF backlight	BL Power supply
4	LEDA	Anode pin of backlight	BL Power supply
5	GND	Power Ground	Power supply
6	RESET	Reset signal	I
7	A0	Data or Command Selection	Power supply
8	SDA	SPI interface Data Input	I/O
9	SCK	serial Synchronous Clock	I
10,11	VCC	Power supply 2.8V	Power supply
12	CSX	Chip select pin	I
13	GND	Power Ground	Power supply
14	NC	Not connected	



5. 极限参数 Absolute Maximum Ratings

参数(Parameter)	符号(Symbol)	最小值(Min)	最大值(Max)	单位(Unit)
逻辑电压(Supply voltage for logic)	V_{CC}	-0.3	3.3	V
输入逻辑电压(Input voltage for logic)	V_{IN}	-0.5	$V_{CC} + 0.3$	V
LED 电流 (Supply current(One LED))	I_{LED}	15	20	mA
工作温度(Operating temperature)	T_{OP}	-20	+70	°C
存储温度(Storage temperature)	T_{ST}	-30	+80	°C

6. 电气参数 Electrical Characteristics

项目 Item	符号 Symbol	最小值 Min	典型值 Typ	最大值 Max	单位 Unit	应用终端 Applicable terminal
逻辑电压(Supply voltage for logic)	V_{CC}	2.5	2.8	3.3	V	V_{DD}
	IOVCC	1.65	1.8	3.3	V	I/O Voltage
输入电压(Input voltage)	V_{IL}	-0.3	-	$0.2 V_{DD}$	V	
	V_{IH}	$0.8 V_{CC}$	-	V_{CC}		
输入漏电流(Input leakage current)	I_{LKG}				μA	
LED 正向电压(LED Forward voltage)	V_f	2.8	3.2	3.4	V	--
输入背光电流(Input backlight current)	I_{LED}	30	40	50	mA	With Four LED



7. 光学参数 Optical Characteristics

项目 ITEM	符号 SYMBOL	条件 CONDITIONS	规格(SPECIFICATIONS)			单位 UNIT	注意 NOTE			
			最小值 MIN	典型值 TYP	最大值 MAX					
亮度 Brightness	B	正常观察 角度 Viewing normal angle	--	--	--	Cd/m ²	所有左边的数据是基于千一显示的产品，仅供参考 All left side data are based on QIANYI's product reference only			
对比度 Contrast Ratio	CR		200	300	--	--				
响应时间 ResponTime	Tr+Tf		--	30	60	Msec				
颜色坐标 CIE Color coordinate	红色 Red	X _R Y _R	-0.05	0.610 0.329	+0.05					
	绿色 Green	X _G Y _G		0.299 0.567						
	蓝色 Blue	X _B Y _B		0.143 0.111						
	白色 White	X _W Y _W		0.308 0.327						
	观察角度 Viewing Angle	水平 Hor.		θ_{x+} θ_{x-}		-- --		45 45	-- --	Deg.
		垂直 Ver.		θ_{y+} θ_{y-}		-- --		45 20	-- --	
均匀性 Uniformity	Un		--	80	--	%				

Note 1: 可视角度的定义 Definition of Viewing Angle:

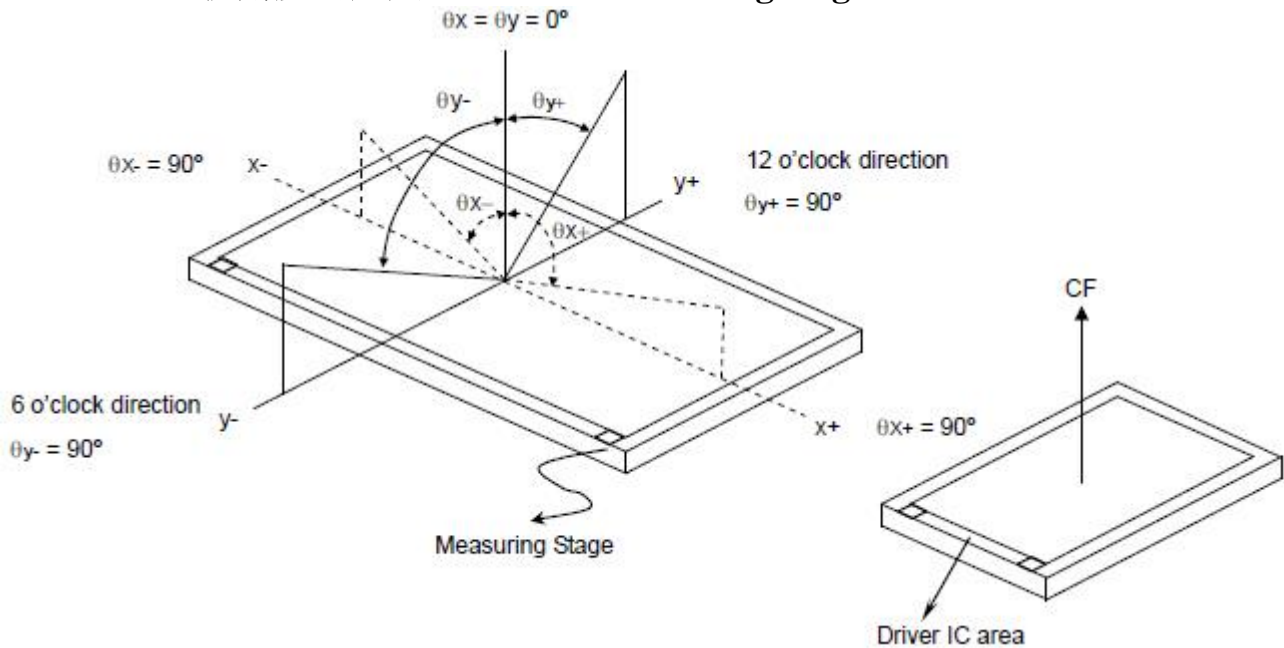

Note 2: 对比度定义 Definition of contrast ratio CR:



$$CR = \frac{\text{Brightness of non-selected dots (white)}}{\text{Brightness of selected dots (black)}}$$

Note 3: 响应时间的定义 Definition of response time (T_R , T_F)

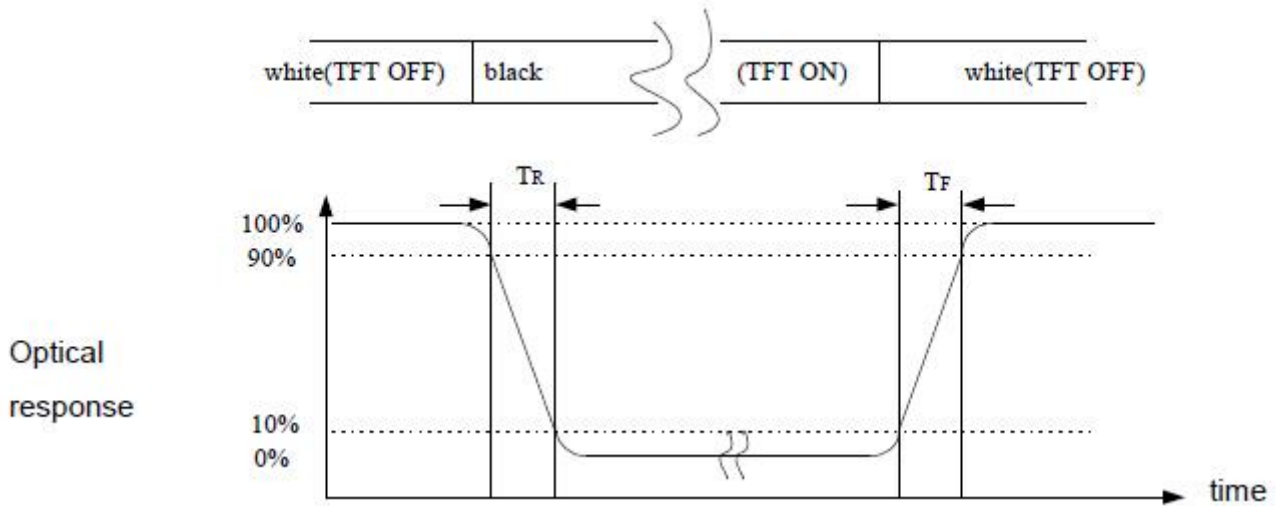

Note 4: 光学测量装置的定义 Definition of optical measurement setup

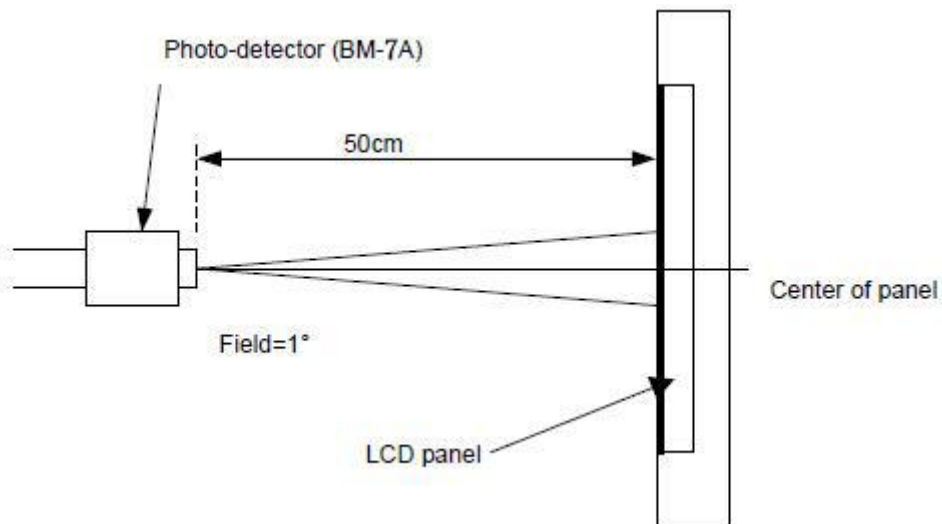



8.时序特性 Timing Characteristics

4-line 串行接口时序特性 4-line Serial Interface Timing Characteristics

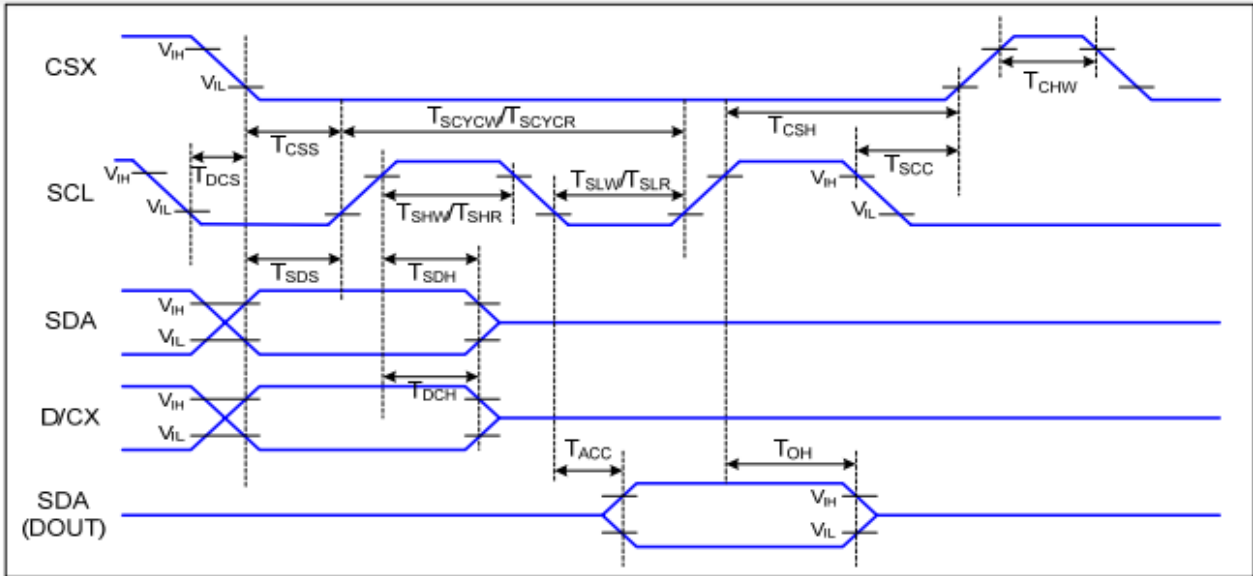

Figure 7 4-line Serial Interface Timing

T_a=25 °C, V_{DDI}=1.65~3.7V, V_{DD}=2.5~4.8V

Signal	Symbol	Parameter	MIN	MAX	Unit	Description
CSX	TCSS	Chip Select Setup Time (Write)	45		ns	
	TCSH	Chip Select Hold Time (Write)	45		ns	
	TCSS	Chip Select Setup Time (Read)	60		ns	
	TSCC	Chip Select Hold Time (Read)	65		ns	
	TCHW	Chip Select "H" Pulse Width	40		ns	
SCL	TSCYCW	Serial Clock Cycle (Write)	66		ns	-Write Command & Data Ram
	TSHW	SCL "H" Pulse Width (Write)	15		ns	
	TSLW	SCL "L" Pulse Width (Write)	15		ns	
	TSCYCR	Serial Clock Cycle (Read)	150		ns	-Read Command & Data Ram
	TSHR	SCL "H" Pulse Width (Read)	60		ns	
	TSLR	SCL "L" Pulse Width (Read)	60		ns	
D/CX	TDCS	D/CX Setup Time	10		ns	
	TDCH	D/CX Hold Time	10		ns	
SDA (DIN) (DOUT)	TSDS	Data Setup Time	10		ns	For Maximum CL=30pF For Minimum CL=8pF
	TSDH	Data Hold Time	10		ns	
	TACC	Access Time	10	50	ns	
	TOH	Output Disable Time	15	50	ns	



9. 初始化建议 Initial code Suggestion

```
LCD_RESET=1;
Delays (1); //Delay 1ms
LCD_RESET=0;
Delays (1); //Delay 1ms
LCD_RESET=1;
Delays (120); //Delay 120ms

//-----End ST7735S Reset Sequence -----//
WriteComm(0x11); //Sleep out
Delay (120); //Delay 120ms
//-----ST7735S Frame Rate-----//
WriteComm(0xB1);
WriteData(0x05);
WriteData(0x3C);
WriteData(0x3C);
WriteComm(0xB2);
WriteData(0x05);
WriteData(0x3C);
WriteData(0x3C);
WriteComm(0xB3);
WriteData(0x05);
WriteData(0x3C);
WriteData(0x3C);
WriteData(0x05);
WriteData(0x3C);
WriteData(0x3C);
//-----End ST7735S Frame Rate-----//
WriteComm(0xB4); //Dot inversion
WriteData(0x03);
//-----ST7735S Power Sequence-----//
WriteComm(0xC0);
WriteData(0x28);
WriteData(0x08);
WriteData(0x04);
WriteComm(0xC1);
WriteData(0XC0);
WriteComm(0xC2);
WriteData(0x0D);
WriteData(0x00);
WriteComm(0xC3);
WriteData(0x8D);
WriteData(0x2A);
WriteComm(0xC4);
WriteData(0x8D);
WriteData(0xEE);
//-----End ST7735S Power Sequence-----//
WriteComm(0xC5); //VCOM
WriteData(0x10);
WriteComm(0x36); //MX, MY, RGB mode
WriteData(0x00);
//-----ST7735S Gamma Sequence-----//
WriteComm(0xE0);
WriteData(0x04);
WriteData(0x22);
WriteData(0x07);
WriteData(0x0A);
WriteData(0x2E);
```



```
WriteData(0x30);
WriteData(0x25);
WriteData(0x2A);
WriteData(0x28);
WriteData(0x26);
WriteData(0x2E);
WriteData(0x3A);
WriteData(0x00);
WriteData(0x01);
WriteData(0x03);
WriteData(0x13);
WriteComm(0xE1);
WriteData(0x04);
WriteData(0x16);
WriteData(0x06);
WriteData(0x0D);
WriteData(0x2D);
WriteData(0x26);
WriteData(0x23);
WriteData(0x27);
WriteData(0x27);
WriteData(0x25);
WriteData(0x2D);
WriteData(0x3B);
WriteData(0x00);
WriteData(0x01);
WriteData(0x04);
WriteData(0x13);
//-----End ST7735S Gamma Sequence-----//
WriteComm(0x3A); //65k mode
WriteData(0x05);
WriteComm(0x29); //Display on
```



10.品质检验标准 LCM Quality Criteria

10.1 外观及功能的检验标准 Visual & Function Inspection Standard

10.1.1 检验条件 Inspection conditions

建议在下列条件下进行检验 Inspection performed under the following conditions is recommended.

温度 Temperature :	25±5℃
湿度 Humidity :	65%±10%RH
视角 Viewing Angle :	正常的视角 Normal viewing Angle.
照明 Illumination:	单颗荧光灯 Single fluorescent lamp (300 to 700Lux)
观察距离 Viewing distance:	30-50 cm

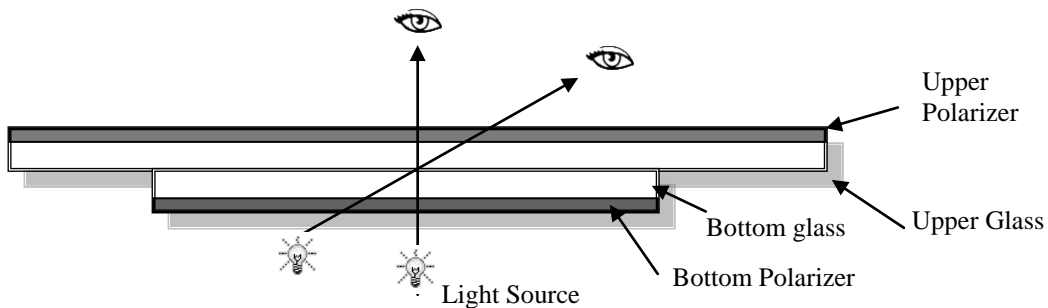

10.1.2 定义 Definition

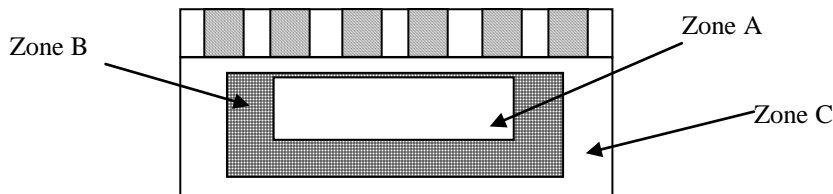

Zone A : 有效显示区域 (显示图像的区域) Effective Viewing Area(Character or Digit can be seen)

Zone B : 观察区 Zone A 除外 Viewing Area except Zone A

Zone C : 外形边框 Outside (Zone A+Zone B) which can not be seen after assembly by customer .)

Note:

一般情况下, 在不影响客户产品装配后的功能或外观, Zone C 的缺损可忽略不计;

As a general rule ,visual defects in Zone C can be ignored when it doesn't effect product function or appearance after assembly by customer.



10.1.3 抽样计划 Sampling Plan

根据 GB / T 2828-2003 II 类标准正常检验；

According to GB/T 2828-2003 ; , normal inspection, Class II

可接受的质量标准 AQL:

主要缺陷 Major defect	次要缺陷 Minor defect
0.65	1.5

LCD: Liquid Crystal Display , TP: Touch Panel , LCM: Liquid Crystal Module

编号 No	需要检查的项目 Items to be inspected	标准 Criteria	缺陷分类 Classification of defects
1	功能缺陷 Functional defects	1. 无显 No display 2. 显示异常 Display abnormally 3. 缺画 Missing vertical, horizontal segment 4. 短路 Short circuit 5. 背光不亮、闪烁或者异常 Back-light no lighting,lickering and abnormal lighting 6. 信号交叉串扰 Cross-Talk 7. 噪声 Noise 8. 色彩对比度不一致 Color contrast	主要缺陷 Major
2	缺少 Missing	缺少的组件 Missing component	
3	外形尺寸 Outline dimension	整体外形尺寸超出图纸是不允许的范围； Overall outline dimension beyond the drawing is not allowed	
4	色调 Color tone	指与样品的色调有差异； Color unevenness, refer to limited sample	次要缺陷 Minor
5	焊接外观 Soldering appearance	良好的焊接，不允许虚焊； Good soldering , Peeling off is not allowed.	
6	玻璃/偏光片 LCD/Polarizer	黑白点/线，划痕，裂纹等。 Black/White spot/line, scratch, crack, etc.	

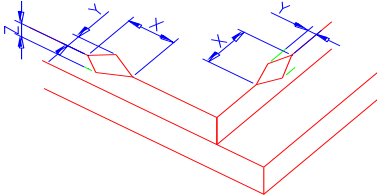
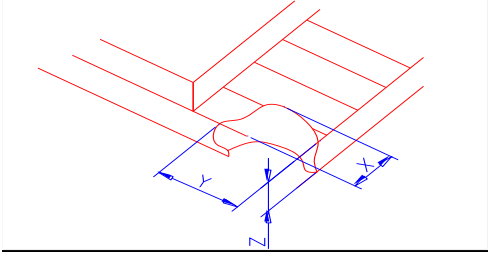
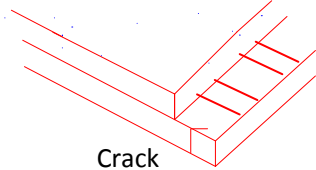

10.1.4 目测检验标准 Criteria (Visual)

编号 Number	项目 Items	标准 Criteria(mm)						
1.0 LCD Crack/Broken 裂痕/破裂 NOTE: X: Length Y: Width Z: Height L: Length of ITO, T: Height of LCD	(1) 玻璃边缘破裂 The edge of LCD broken	 <table border="1" data-bbox="841 640 1385 797"> <thead> <tr> <th>X</th> <th>Y</th> <th>Z</th> </tr> </thead> <tbody> <tr> <td>≤1.5mm</td> <td><Inner border line of the seal</td> <td>≤T</td> </tr> </tbody> </table>	X	Y	Z	≤1.5mm	<Inner border line of the seal	≤T
	X	Y	Z					
	≤1.5mm	<Inner border line of the seal	≤T					
(2) 玻璃蹦角 LCD corner broken	 <table border="1" data-bbox="901 1151 1326 1227"> <thead> <tr> <th>X</th> <th>Y</th> <th>Z</th> </tr> </thead> <tbody> <tr> <td>≤1.5mm</td> <td>≤1.0mm</td> <td>≤T</td> </tr> </tbody> </table>	X	Y	Z	≤1.5mm	≤1.0mm	≤T	
X	Y	Z						
≤1.5mm	≤1.0mm	≤T						
(3) 玻璃裂纹 LCD crack	 <p>Crack 不允许; Not allowed</p>							

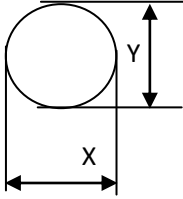

编号 Number	项目 Items	标准 Criteria (mm)																																														
2.0	点缺陷 Spot defect  $\Phi=(X+Y)/2$	① 光点 (LCD/TP/偏光片黑/白点, 轻点, 针孔, 凹陷, 彩点) light dot (LCD/TP/Polarizer black/white spot, light dot, pinhole, dent, stain) <table border="1"> <thead> <tr> <th rowspan="2">Zone Size (mm)</th> <th colspan="3">允许数量 Acceptable Qty</th> </tr> <tr> <th>A</th> <th>B</th> <th>C</th> </tr> </thead> <tbody> <tr> <td>$\Phi \leq 0.10$</td> <td colspan="3">忽略 Ignore</td> </tr> <tr> <td>$0.10 < \Phi \leq 0.15$</td> <td colspan="3">2</td> </tr> <tr> <td>$0.15 < \Phi \leq 0.2$</td> <td colspan="3">1</td> </tr> <tr> <td>$0.2 < \Phi$</td> <td colspan="3">0</td> </tr> </tbody> </table> ② 暗点 (LCD/TP/偏光片漏光昏暗的点、黑点) Dim spot (LCD/TP/Polarizer dim dot, light leakage, dark spot) <table border="1"> <thead> <tr> <th rowspan="2">Zone Size (mm)</th> <th colspan="3">允许数量 Acceptable Qty</th> </tr> <tr> <th>A</th> <th>B</th> <th>C</th> </tr> </thead> <tbody> <tr> <td>$\Phi \leq 0.1$</td> <td colspan="3">忽略 Ignore</td> </tr> <tr> <td>$0.1 < \Phi \leq 0.2$</td> <td colspan="3">2</td> </tr> <tr> <td>$0.2 < \Phi \leq 0.3$</td> <td colspan="3">1</td> </tr> <tr> <td>$\Phi > 0.3$</td> <td colspan="3">0</td> </tr> </tbody> </table>	Zone Size (mm)	允许数量 Acceptable Qty			A	B	C	$\Phi \leq 0.10$	忽略 Ignore			$0.10 < \Phi \leq 0.15$	2			$0.15 < \Phi \leq 0.2$	1			$0.2 < \Phi$	0			Zone Size (mm)	允许数量 Acceptable Qty			A	B	C	$\Phi \leq 0.1$	忽略 Ignore			$0.1 < \Phi \leq 0.2$	2			$0.2 < \Phi \leq 0.3$	1			$\Phi > 0.3$	0		
	Zone Size (mm)	允许数量 Acceptable Qty																																														
A		B	C																																													
$\Phi \leq 0.10$	忽略 Ignore																																															
$0.10 < \Phi \leq 0.15$	2																																															
$0.15 < \Phi \leq 0.2$	1																																															
$0.2 < \Phi$	0																																															
Zone Size (mm)	允许数量 Acceptable Qty																																															
	A	B	C																																													
$\Phi \leq 0.1$	忽略 Ignore																																															
$0.1 < \Phi \leq 0.2$	2																																															
$0.2 < \Phi \leq 0.3$	1																																															
$\Phi > 0.3$	0																																															
	线缺陷 LCD/偏光片黑/白线、划痕、彩色 Line defect (LCD/Polarizer black/white line, scratch, stain)	<table border="1"> <thead> <tr> <th>Width(mm)</th> <th>Length(mm)</th> <th>允许数量 Acceptable Qty</th> </tr> </thead> <tbody> <tr> <td>$\Phi \leq 0.03$</td> <td>忽略 Ignore</td> <td>忽略 Ignore</td> </tr> <tr> <td>$0.03 < W \leq 0.05$</td> <td>$L \leq 2.0$</td> <td>1</td> </tr> <tr> <td>$0.05 < W$</td> <td colspan="2">0</td> </tr> </tbody> </table>	Width(mm)	Length(mm)	允许数量 Acceptable Qty	$\Phi \leq 0.03$	忽略 Ignore	忽略 Ignore	$0.03 < W \leq 0.05$	$L \leq 2.0$	1	$0.05 < W$	0																																			
Width(mm)	Length(mm)	允许数量 Acceptable Qty																																														
$\Phi \leq 0.03$	忽略 Ignore	忽略 Ignore																																														
$0.03 < W \leq 0.05$	$L \leq 2.0$	1																																														
$0.05 < W$	0																																															
3.0	偏光片划伤 Polarizer scratch	<table border="1"> <thead> <tr> <th>Width(mm)</th> <th>Length(mm)</th> <th>允许数量 Acceptable Qty</th> </tr> </thead> <tbody> <tr> <td>$W \leq 0.03$</td> <td>忽略 Ignore</td> <td>忽略 Ignore</td> </tr> <tr> <td>$0.03 < W \leq 0.05$</td> <td>$L \leq 2$</td> <td>2</td> </tr> <tr> <td>$0.05 < W \leq 0.10$</td> <td>$L \leq 1$</td> <td>1</td> </tr> <tr> <td colspan="2">$W > 0.10\text{mm}$ or $L > 2\text{mm}$</td> <td>0</td> </tr> </tbody> </table>	Width(mm)	Length(mm)	允许数量 Acceptable Qty	$W \leq 0.03$	忽略 Ignore	忽略 Ignore	$0.03 < W \leq 0.05$	$L \leq 2$	2	$0.05 < W \leq 0.10$	$L \leq 1$	1	$W > 0.10\text{mm}$ or $L > 2\text{mm}$		0																															
Width(mm)	Length(mm)	允许数量 Acceptable Qty																																														
$W \leq 0.03$	忽略 Ignore	忽略 Ignore																																														
$0.03 < W \leq 0.05$	$L \leq 2$	2																																														
$0.05 < W \leq 0.10$	$L \leq 1$	1																																														
$W > 0.10\text{mm}$ or $L > 2\text{mm}$		0																																														

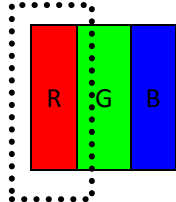

	偏光片气泡 Polarizer Bubble	<table border="1"> <tr> <th>Zone Size (mm)</th> <th>允许数量 Acceptable Qty</th> </tr> <tr> <td>$\Phi \leq 0.1$</td> <td>忽略 Ignore</td> </tr> <tr> <td>$0.1 < \Phi \leq 0.2$</td> <td>2</td> </tr> <tr> <td>$0.2 < \Phi \leq 0.3$</td> <td>1</td> </tr> <tr> <td>$0.3 < \Phi$</td> <td>0</td> </tr> </table>	Zone Size (mm)	允许数量 Acceptable Qty	$\Phi \leq 0.1$	忽略 Ignore	$0.1 < \Phi \leq 0.2$	2	$0.2 < \Phi \leq 0.3$	1	$0.3 < \Phi$	0			
Zone Size (mm)	允许数量 Acceptable Qty														
$\Phi \leq 0.1$	忽略 Ignore														
$0.1 < \Phi \leq 0.2$	2														
$0.2 < \Phi \leq 0.3$	1														
$0.3 < \Phi$	0														
4.0	贴片电子元器件 SMT	根据<电子组件接受 IPC-A-610C 2 级标准>。组件丢失或功能缺陷是主要的缺陷，其他是次要缺陷。According to the <Acceptability of electronic assemblies> IPC-A-610C class 2 standard. Component missing or function defect are Major defect, the others are Minor defect.													
5.0	TFT	<table border="1"> <thead> <tr> <th>区分 distinguish</th> <th>类型 type</th> <th>允许数量 Acceptable Qty</th> </tr> </thead> <tbody> <tr> <td rowspan="2">亮点 Bright dot</td> <td>任何颜色 Any color window</td> <td>0</td> </tr> <tr> <td>相邻的亮点 Adjacent Bright dot</td> <td>0</td> </tr> <tr> <td rowspan="2">黑点 Dark dot</td> <td>黑点 Dark dot</td> <td>1</td> </tr> <tr> <td>相邻黑点 Adjacent Dark dot</td> <td>0</td> </tr> </tbody> </table> <p>Note: the red (R), green, blue (G), (B) 3 points constitute a pixel</p> 	区分 distinguish	类型 type	允许数量 Acceptable Qty	亮点 Bright dot	任何颜色 Any color window	0	相邻的亮点 Adjacent Bright dot	0	黑点 Dark dot	黑点 Dark dot	1	相邻黑点 Adjacent Dark dot	0
区分 distinguish	类型 type	允许数量 Acceptable Qty													
亮点 Bright dot	任何颜色 Any color window	0													
	相邻的亮点 Adjacent Bright dot	0													
黑点 Dark dot	黑点 Dark dot	1													
	相邻黑点 Adjacent Dark dot	0													

10.1.5 功能性标准 Criteria (functional items)

项目 Items	标准 Criteria
无显 No display	不允许; Not allowed
显示异常 Display abnormally	不允许; Not allowed
缺画 Missing vertical, horizontal	不允许; Not allowed
组件分离 Segment	不允许; Not allowed
短路 Short circuit	不允许; Not allowed
背光不亮 Back-light no lighting,	不允许; Not allowed
背光闪烁或异常 Flickering and abnormal lighting	不允许; Not allowed
信号交叉串扰 Cross-Talk	不允许; Not allowed
噪声 Noise	不允许; Not allowed
色彩对比度不一致 Color contrast	不允许; Not allowed
玻璃表面污垢 The LCD surface dirt	如果客户不能自行擦除干净, 也是不可接受的; If you cannot use smudgy surface air clean and clear, coco is not acceptable
缺少元器件 Components off	不允许; Not allowed
FPC&PCB 不良 FPC&PCB undesirable	不允许; Not allowed
铁框支架变形 Iron frame deformation	不允许; Not allowed



10.2 可靠性实验 Reliability Test

项目 ITEM	条件 Condition	样品数量 Sample size	标准 Criterion
高温储存 High Temp. Storage	+80°C ± 2°C, 120 小时 hrs	5pcs	检查后2~4小时存储在室温下，该样品应无缺陷： 1. 液晶显示器无气泡； 2. 液晶无漏液； 3. 显示正常； 4. 不缺少部件； 5. 表面应无损伤； 6. 线性度测试仪检测对比度必须不超过10%。 7. 线性度测试仪检测电源不超过10%。 Inspection after 2~4hours storage at room temperature, the sample shall be free from defects: 1.Air bubble in the LCD; 2.Sealleak; 3.Non-display; 4.Missing segments; 5. The surface shall be free from damage. 6. Contrast must be no more than 10% by the linearity tester. 7. Power must be no more than 10% by the linearity tester.
低温储存 Low Temp. Storage	-30°C ± 2°C, 120 小时 hrs	5pcs	
高温运行 High Temp. Operation	+70°C ± 2°C, 72 小时 hrs	5pcs	
低温运行 Low Temp. Operation	-20°C ± 2°C, 72 小时 hrs	5pcs	
湿度运行 Humidity operation	40°C, 90%RH, 72 小时 hrs	5pcs	
湿度储存 Humidity storage	70°C, 90%RH, 72 小时 hrs	5pcs	
温湿度循环 Temp humidity cycles	25°C → Calefaction/3hrs → 60°C/9hrs → Descend temp/3hrs 25°C/9hrs → 90%RH Total:10 cycles	5pcs	
冷热冲击循环 Thermal shock	-30°C/30min → 80°C/30mins Total:10 cycles	5pcs	
震动 Vibration	Amplitude between 10 and 150Hz: 3G(100m/s ²)/2hrs for each direction(X,Y,Z)	1Carton-box	
跌落测试 Drop test	1.5m, 10times	1Carton-box	
静电测试 ESD	1.Contact discharge method ± 6KV, 150pF/330Ω 10times	5pcs	1. 经过测试，没有任何有缺陷的表现或电气性能。 2. 在可以接受时，所有有缺陷的现象在ESD复位后消失。 1. After testing, there are no any defective appearances or electrical properties. 2. It can be acceptable when all defective ESD disappears in the RESET.
	2.Air discharge method ± 8KV, 150pF/330Ω 10times	5pcs	



10.3 安全说明 Safety instructions

10.3.1 如果液晶面板断裂，小心不要让任何液晶物质进入到口中；

If the LCD panel breaks, be careful not to get any liquid crystal substance in your mouth.

10.3.2 如果液晶物质触及你的皮肤或衣物，请立即用肥皂和水清洗干净；

If the liquid crystal substance touches your skin or clothes, please wash it off immediately by using soap and water.

10.4 模组使用注意事项 Handling Precautions

10.4.1 客户在做结构设计时，请保证机壳开窗尺寸比触摸屏 V.A 单边少 0.3mm，泡棉开窗尺寸比触摸屏 V.A 单边大 0.2mm；

Customers do structural design, please ensure the cabinet window size smaller than the touch screen VA unilateral 0.3mm. Foam window size larger than 0.2mm unilateral touchscreen V.A

10.4.2 防止静电损坏集成电路

Avoid static electricity damaging the LSI.

10.4.3 不要从模块中拆下玻璃面板或铁框支架

Do not remove the panel or frame from the module .

10.4.4 显示屏的偏光片是很脆弱的。所以请注意要非常小心，避免损坏；

The polarizing plate of the display is very fragile . So, please handle it very carefully.

10.4.5 不要用干布擦拭偏光片，因为很容易刮伤到它的表面；

Do not wipe the polarizing plate with a dry cloth, as it may easily scratch the surface of the plate.

10.4.6 显示颜色和背景色调有可能随着储存温度范围的变化而发生改变；

The color tone of display and background of LCM has the possibility to be changed in the storage temperature range.

10.4.7 注意工作使用环境，产品可能会被静电所损坏；

Pay attention to the working environment, as the element may be destroyed by static electricity.

--确保使用作业人员身体可靠的接地；

Be sure to ground human body and electric appliance during work.

--避免在干燥的环境中作业，减少静电的损害；

Avoid working in a dry environment to minimize the generations of static electricity.

--在作业过程中，快速剥离保护膜时可能会引起静电；

Static electricity may be generated when the protective film is fast peeled off.

10.4.8 当焊接 LCM 端子时，确保使用交流电源的烙铁不漏电；

When soldering the terminal of LCM, make certain the AC power source of soldering iron does not leak.

10.4.9 潮湿的环境可能引起玻璃 ITO 的腐蚀，在使用中，请确保湿度在 50%以下。

Humid environment may cause a bad ITO glass corrosion, in use, make sure the humidity is below 50%.

10.4.10 如果液晶显示模组的表面被污染，可以使用柔软的无尘布在表面上轻轻的擦拭。如果是严重的污染，可以用无尘布蘸上酒精轻轻擦拭。特别是不可使用可能损坏偏光片的溶剂（例如：水/酮）If the display surface becomes contaminated ,breathe on the surface and gently wipe it with a soft-dry- clean cloth .If it is heavily contaminated ,moisten cloth with the following solvent(ex:Ethyl alcohol).Solvents other than those above-mentioned may damage the polarizer(Especially ,do not use them .ex: Warter / Ketone)

10.5 使用说明 Operation instructions

10.5.1 推荐使用 在规定的电压范围内驱动液晶显示面板，尝试调整工作电压为达到最佳的对比度，在不同的温度液晶显示面板的颜色和对比度会有所不同；

It is recommended to drive the LCD within the specified voltage limits, try to adjust the operating voltage for the optimal contrast, the color and contrast of LCD panel will varies at different temperature.

10.5.2 在较低的工作温度范围液晶的响应时间会大大延迟。但这并不意味着液晶会失灵，使它返回到指定的温度范围他将会恢复到正常的状态；



Response time is greatly delayed at low operating temperature range. However, this does not mean the LCD will be out of the order, It will recover when it returns to the specified temperature range.

10.5.3 液晶显示模块在工作时如果显示区遭到硬物压力，液晶显示模块将会变得显示异常；

If the display area is pushed hard during operation, the display will become abnormal.

10.5.4 不在特定条件下的环境中使用 LCD，可能会导致液晶的损伤和寿命的缩短；

Do not operate the LCD at the environments over the specified conditions, this may cause damage on the LCD and shorten the lifetime.

10.6 存储方法 Storage instructions:

10.6.1 将液晶显示模组存储在密封的聚乙烯袋中；

Store LCDs in a sealed polyethylene bag.

10.6.2 将液晶显示模组放置在黑暗的地方，不要暴露在阳光或者日光灯下，保持 0℃到 35℃之间的温度；

Store LCDs in a dark place, Do not expose to sunlight or fluorescent light. Keep the temperature between 0°C and 35°C.

10.6.3 避免接触任何其他震动的物体，建议将他们存储在固定的容器中，便于搬运；

Avoid the polarizer touch any other object, (It is recommended to store them in the container in which they were shipped.)

10.7 保修期限 Limited Warranty

10.7.1 按照检查验收标准(或商定好的要求)，发现产品有缺陷的，从产品喷墨打印的生产日期起，我司提供 12 个月的产品维修保障服务；

will replace or repair any of its LCD modules, which are found to be defective, when inspected in accordance with LCM acceptance standards (copies available upon request) for a period of 12 months from ink- print date on product

10.7.2 任何有缺陷的产品必须从收到货后 60 天内退回，以送货单据做为计算日期的依据；品质责任区分依据(9.1,9.2)；

Any defects must be returned to within 60 days since ship-out. Confirmation of such date shall be based on freight documents. The warranty liability of was am limited to repair and/or replacement on defects above (7.1,7.2)

10.7.3 如果是因为保护预防措施不当，造成下述的问题，将不提供保修：

No warranty can be granted if the precautions stated above have been disregarded. The typical samples are as below:

--液晶显示屏破裂/裂纹 LCD glass crack/break

-- PCB 插座损坏或修改 PCB outlet is damaged or modified.

--损坏的 PCB 导体 PCB conductors damaged.

--电路经过人为的研磨、雕刻或绘画漆修饰 Circuit modified with by grinding, engraving or painting varnish.

-- FPC 有断裂纹 FPC crack

10.7.4 必须将有缺陷的模块标识清楚问题现象，必须将安装的任何连接物体彻底分离清除，而不损坏 PCB 插座、电路和端子，液晶显示屏必须用专用的包装盒包装运输；

Modules must be returned with sufficient description of the failures of defects. Any connectors or cable installed by the customer must be removed completely without damaging the PCB outlet, conductors and terminals. Modules must be packed with the container in which they were shipped.



11. 包装方法 Packing method

包装示意图 Package picture:

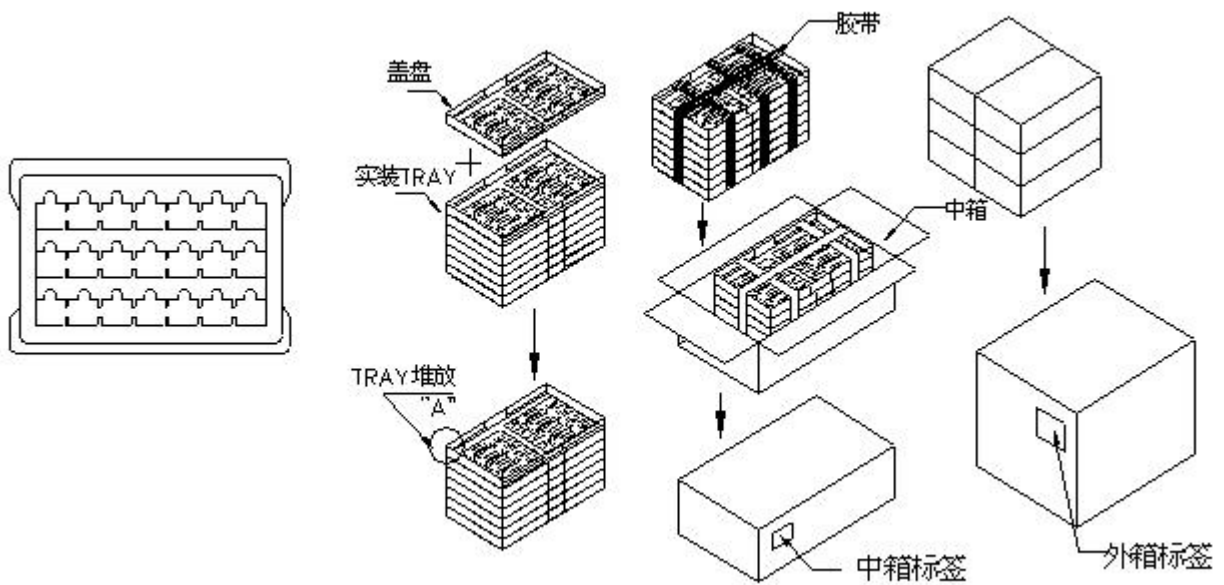

详细信息请咨询我们的技术部门

Please consult our technical department for detail information.