



4. ABSOLUTE MAXIMUM RATINGS

Parameter	Symbol	Min	Max	Unit
Supply voltage for logic	V_{CC}	-0.3	3.3	V
Input voltage for logic	V_{IN}	-0.5	$V_{CC} + 0.3$	V
Supply current (One LED)	I_{LED}		20	mA
Operating temperature	T_{OP}	-10	+60	°C
Storage temperature	T_{ST}	-20	+70	°C

5. ELECTRICAL CHARACTERISTICS

Item	Symbol	Min	Typ	Max	Unit	Applicable terminal
Supply voltage for logic	V_{CC}	2.3	2.8	3.3	V	V_{DD}
Supply voltage for digital	VDDIO	1.65	1.8	3.3	V	IOVCC
Input voltage	V_{IL}	-0.3	-	$0.2 V_{CC}$	V	
	V_{IH}	$0.8 V_{CC}$	-	V_{CC}	V	
I/O leakage current	I_{LKG}	-1		1	μA	
LED Forward voltage	V_f	3.0	3.2	3.4	V	--
Input backlight current	I_{LED}	-	18	20	mA	With One LED



6. TOUCH PANEL SPECIFICATIONS

6.1 Electrical Characteristics

ITEM	SPECIFICATIONS			UNIT	REMARK
	MIN.	TYP.	MAX		
Terminal Resistance	200	-	900	ohm	X(Film side)
	200	-	900	ohm	Y(Glass side)
Insulation Resistance	20	-	-	Mohm	DC 25V 1min
Operating Voltage	-	5	-	V	DC

6.2 Optical Characteristics

ITEM	SPECIFICATIONS			UNIT	REMARK
	MIN.	TYP.	MAX		
Response Time	-	-	10	ms	100kohm pull-up
Light Transparency	80	-	-	%	

6.3 Mechanical Characteristics

ITEM	SPECIFICATIONS			UNIT	REMARK
	MIN.	TYP.	MAX		
Operation Force	-	20	100	gf	Note1
Surface Hardness	3	-	-	H	
Pen Sliding Durability	30,000			times	Note2
Hitting Durability	300,000			times	Note3

Note 1: Do not operate it with a thing except a polyacetal pen (tip R0.8mm or less) or a finger, especially those with hard or sharp tips such as a ball point pen or a mechanical pencil. Depending on the pitch & the dimension of the spacer dots in between.

Note 2: Measurement for surface area.

-Scratch 30,000 times straight line on the film with a stylus change every 10,000 times.

-Force: 100gf.

-Speed: 60mm/sec.

-Stylus: R0.8 polyacetal tip.

Note 3: Hit 300,000 times on the film with an R12.5mm tip.

-Force: 100gf.

-Speed: 2 times/sec.

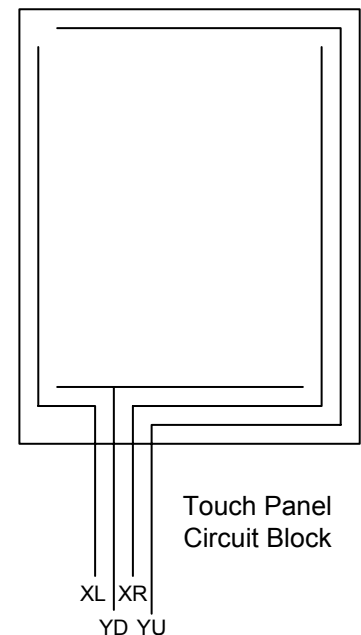



7. OPTICAL CHARACTERISTICS

ITEM	SYMBOL	CONDITIONS	SPECIFICATIONS			UNIT	NOTE	
			MIN.	TYP.	MAX			
Brightness	B	Viewing normal angle		250	--	Cd/m ²	All left side data are based on BOOYI's product reference only	
Contrast Ratio	CR		--	800	--	--		
Response Time	Tr+Tf		--	40	--	ms		
CIE Color coordinate	Red		X _R	0.640	0.660	0.680		
			Y _R	0.305	0.325	0.345		
	Green		X _G	0.251	0.271	0.291		
			Y _G	0.576	0.596	0.616		
	Blue		X _B	0.112	0.132	0.152		
			Y _B	0.105	0.125	0.145		
White	X _w		0.276	0.296	0.316			
	Y _w	0.313	0.333	0.353				
Viewing Angle	Hor.	θ_{x+}	80	85	--	Deg.		
		θ_{x-}	80	85	--			
	Ver.	θ_{y+}	80	85	--			
		θ_{y-}	80	85	--			
Uniformity	Un		--	80	%			

Note 1 : Definition of Viewing Angle θ_x and θ_y :

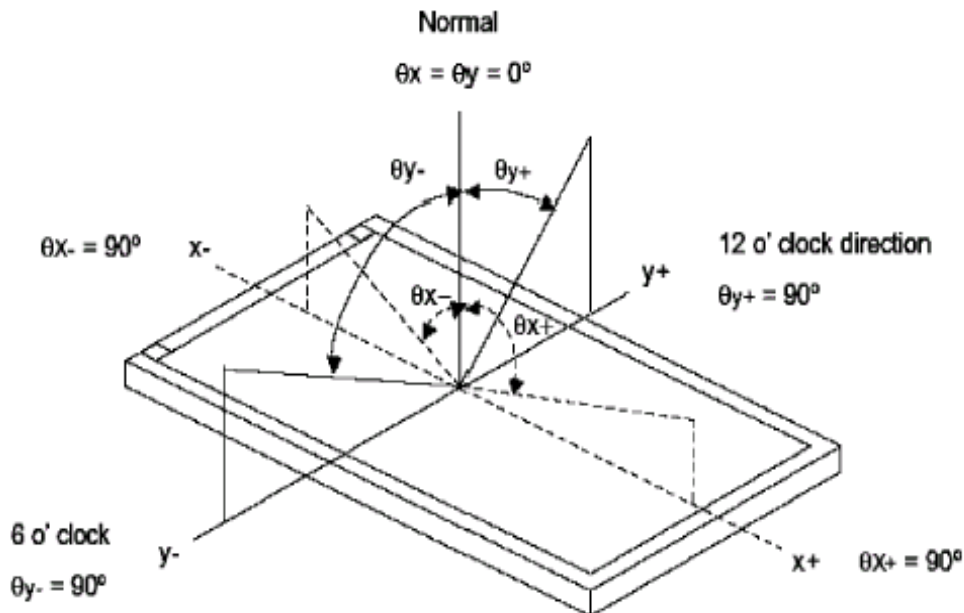



Note 2: Definition of contrast ratio CR:

$$CR = \frac{\text{Brightness of non-selected dots (white)}}{\text{Brightness of selected dots (black)}}$$

Note 3: Definition of response time (T_R , T_F)

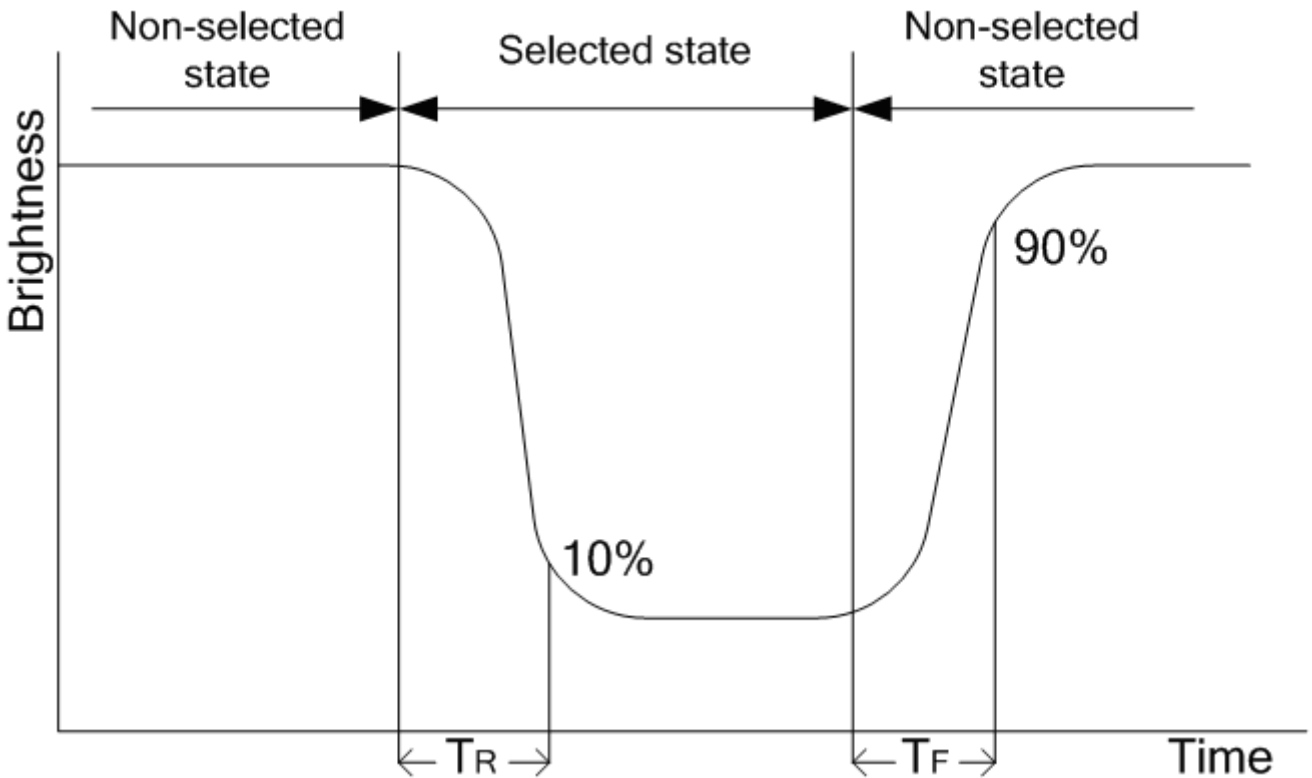



The brightness test equipment setup

20mA Field=2° (As measuring "black" image, field=2° is the best testing condition)

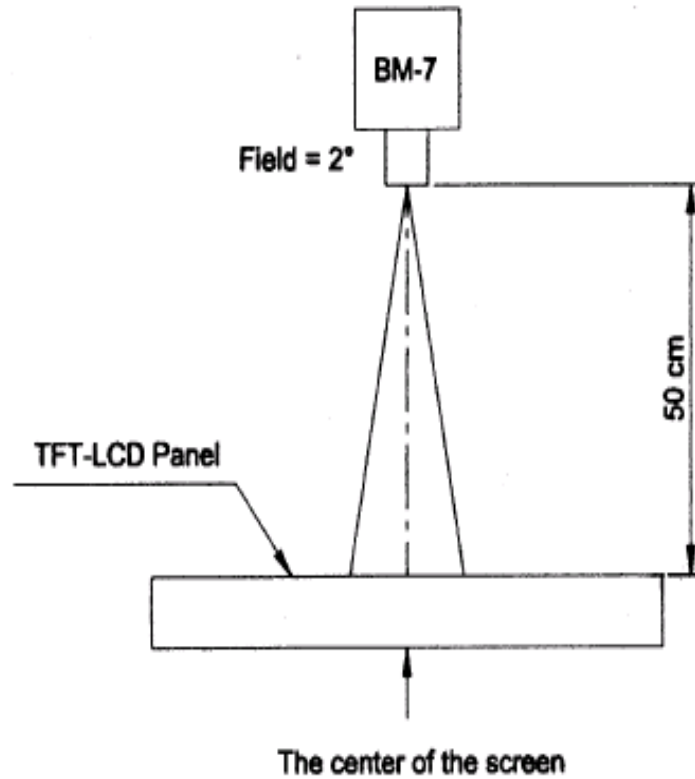

Note 4 :

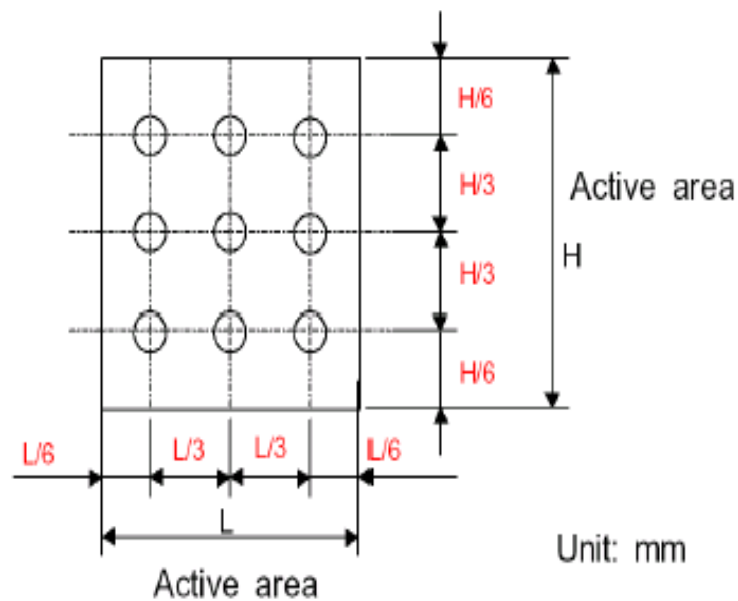



8. MCU Interface Pin Function

NO.	SYMBOL	Description				I/O
1	LEDK	LED Cathode				Power supply
2	LEDA	LED Anode				Power supply
3	YU	Touch Panel Control Pin				I
4	XR					I
5	YD					I
6	XL					I
7	VDD	Power supply (2.5~3.3V)				Power supply
8	VDDI	Power supply (1.65~3.3V)				Power supply
9	IM3	only for SPI,if not used please connect to VSS				I
10	IM2	IM2	IM1	IM0	SYS MODE	I
		0	0	0	8 bits MPU	
11	IM1	0	0	1	16bits MPU	I
		0	1	0	24 bits MPU	
12	IM0	0	1	1	RGB+SPI	I
13	SDO	Serial data output pin and used for the DBI type C mode				O
14	SDI	Serial data input pin and used for the DBI type C mode.				I/O
15	DCX	Command/Data Select				I
16	WRX	Write signal				I
17	RDX	Read signal				I
18	CSX	Chip Select				I
19	RESX	LCD RESET TERMINAL ACITVE"L"				I
20~43	DB23~DB0	RGB DATA BUS				I/O
44	DEN	RGB I/F Data Enable signal				I
45	GND	Ground				Power supply
46	PCLK	RGB I/F Dot Clock Signa				I
47	GND	Ground				Power supply
48	HS	RGB I/F Line synchronous signal				I
49	VS	RGB I/F Frame synchronous signal				I
50	TE	Output a frame head pulse signal				O
51	LED-PWM	Backlight On/Off control pin				O



9. BLOCK DIAGRAM

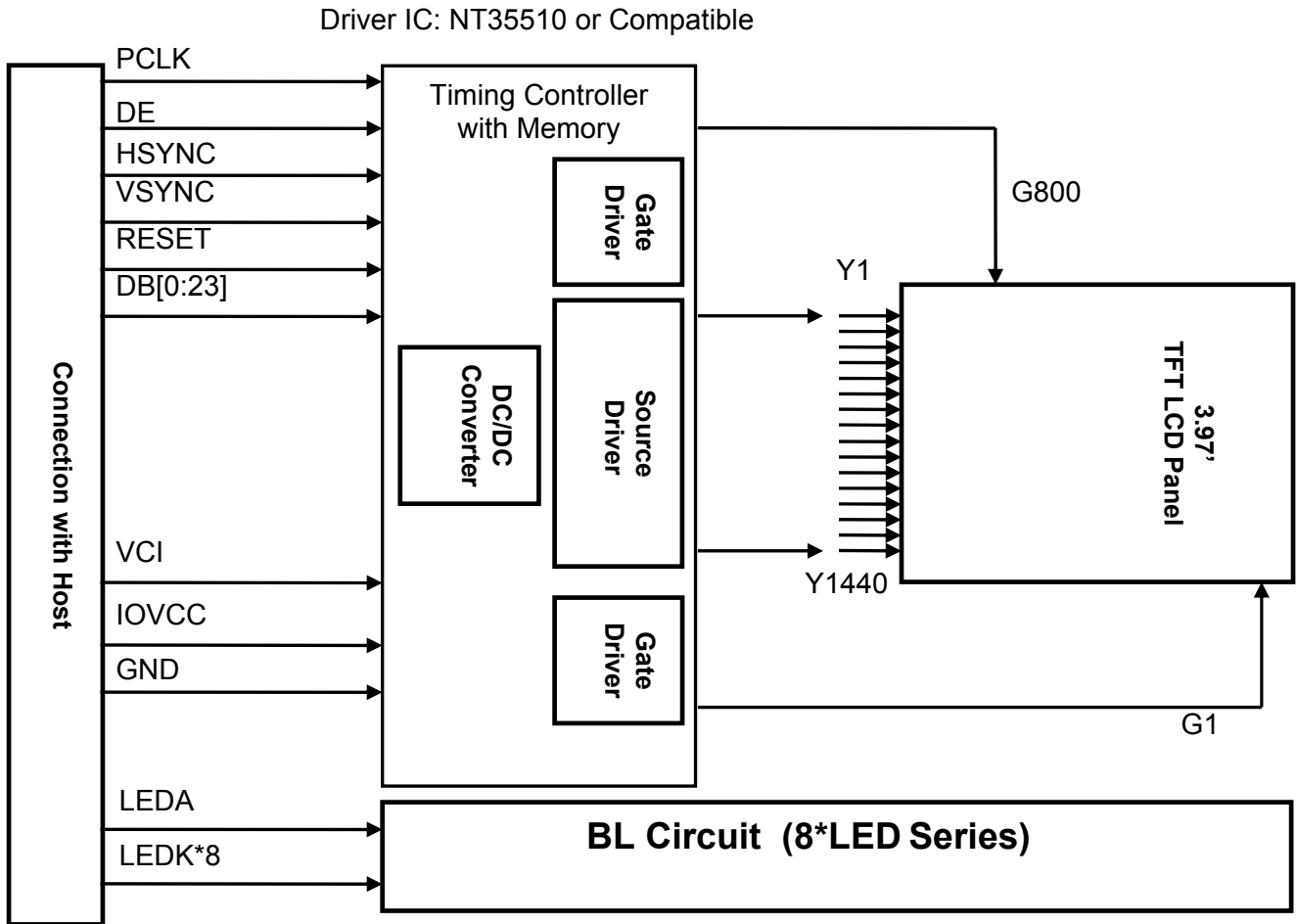



10.LCM Quality Criteria

10.1 VISUAL & FUNCTION INSPECTION STANDARD

10.1.1 Inspection conditions

Inspection performed under the following conditions is recommended.

Temperature : 25±5℃

Humidity : 65%±10%RH

Viewing Angle : Normal viewing Angle.

Illumination: Single fluorescent lamp (300 to 700Lux)

Viewing distance:30-50cm

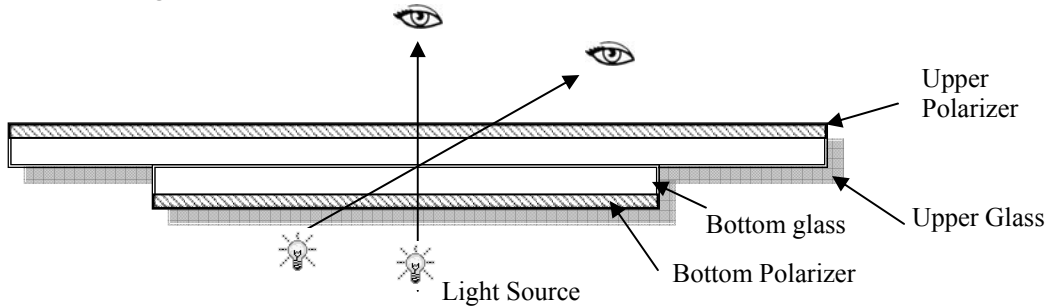

10.1.2 Definition

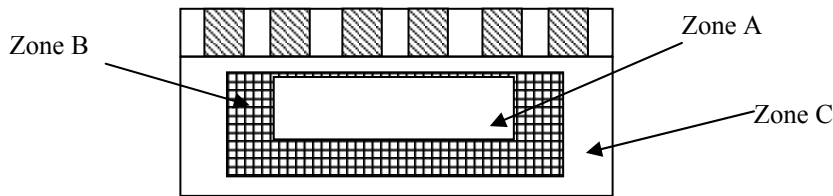

Zone A : Effective Viewing Area(Character or Digit can be seen)

Zone B : Viewing Area except Zone A

Zone C : Outside (Zone A+Zone B) which can not be seen after assembly by customer .)

Note:

As a general rule ,visual defects in Zone C can be ignored when it doesn't effect product function or appearance after assembly by customer.

10.1.3 Sampling Plan

According to GB/T 2828-2003 ; , normal inspection, Class II

AQL:

Major defect	Minor defect
0.40	0.65

LCD: Liquid Crystal Display , TP: Touch Panel , LCM: Liquid Crystal Module

No	Items to be inspected	Criteria	Classification of defects
1	Functional defects	1) No display 2) Display abnormally 3) Missing vertical, horizontal segment 4) Short circuit 5) Back-light no lighting, flickering and abnormal lighting 6)Cross-Talk 7)Noise 8)Color contrast	Major
2	Missing	Missing component	
3	Outline dimension	Overall outline dimension beyond the drawing is not allowed	



4	Color tone	Color unevenness, refer to limited sample	Minor
5	Soldering appearance	Good soldering , Peeling off is not allowed.	
6	LCD/Polarizer	Black/White spot/line, scratch, crack, etc.	

10.1.4 Criteria (Visual)

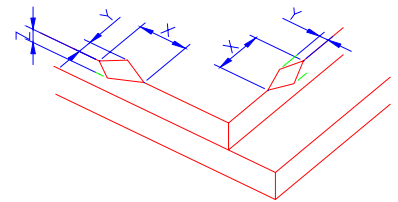
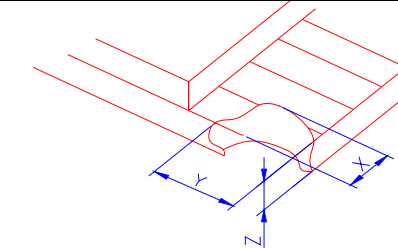
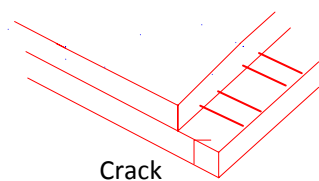
Number	Items	Criteria(mm)						
1.0 LCD Crack/Broken NOTE: X: Length Y: Width Z: Height L: Length of ITO, T: Height of LCD	(1) The edge of LCD broken	 <table border="1" data-bbox="845 627 1388 784"> <tr> <td>X</td> <td>Y</td> <td>Z</td> </tr> <tr> <td>≤2.0mm</td> <td><Inner border line of the seal</td> <td>≤T</td> </tr> </table>	X	Y	Z	≤2.0mm	<Inner border line of the seal	≤T
	X	Y	Z					
	≤2.0mm	<Inner border line of the seal	≤T					
(2)LCD corner broken	 <table border="1" data-bbox="893 1052 1340 1142"> <tr> <td>X</td> <td>Y</td> <td>Z</td> </tr> <tr> <td>≤2.0 mm</td> <td>≤2.0mm</td> <td>≤T</td> </tr> </table>	X	Y	Z	≤2.0 mm	≤2.0mm	≤T	
X	Y	Z						
≤2.0 mm	≤2.0mm	≤T						
(3) LCD crack	 <p>Crack Not allowed</p>							

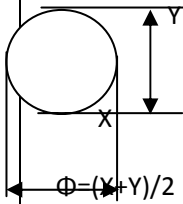

Number	Items	Criteria (mm)																							
2.0	Spot defect 	① light dot (LCD/TP/Polarizer black/white spot, light dot, pinhole, dent, stain)																							
		<table border="1"> <thead> <tr> <th rowspan="2">Zone Size (mm)</th> <th colspan="3">Acceptable Qty</th> </tr> <tr> <th>A</th> <th>B</th> <th>C</th> </tr> </thead> <tbody> <tr> <td>$\Phi \leq 0.1$</td> <td colspan="3">Ignore</td> </tr> <tr> <td>$0.1 < \Phi \leq 0.2$</td> <td colspan="3">2</td> </tr> <tr> <td>$0.2 < \Phi \leq 0.3$</td> <td colspan="3">1</td> </tr> <tr> <td>$\Phi > 0.3$</td> <td colspan="3">0</td> </tr> </tbody> </table>	Zone Size (mm)	Acceptable Qty			A	B	C	$\Phi \leq 0.1$	Ignore			$0.1 < \Phi \leq 0.2$	2			$0.2 < \Phi \leq 0.3$	1			$\Phi > 0.3$	0		
Zone Size (mm)	Acceptable Qty																								
	A	B	C																						
$\Phi \leq 0.1$	Ignore																								
$0.1 < \Phi \leq 0.2$	2																								
$0.2 < \Phi \leq 0.3$	1																								
$\Phi > 0.3$	0																								
		② Dim spot (LCD/TP/Polarizer dim dot, light leakage, dark spot)																							
		<table border="1"> <thead> <tr> <th rowspan="2">Zone Size (mm)</th> <th colspan="3">Acceptable Qty</th> </tr> <tr> <th>A</th> <th>B</th> <th>C</th> </tr> </thead> <tbody> <tr> <td>$\Phi \leq 0.1$</td> <td colspan="3">Ignore</td> </tr> <tr> <td>$0.1 < \Phi \leq 0.2$</td> <td colspan="3">2</td> </tr> <tr> <td>$0.2 < \Phi \leq 0.3$</td> <td colspan="3">1</td> </tr> <tr> <td>$\Phi > 0.3$</td> <td colspan="3">0</td> </tr> </tbody> </table>	Zone Size (mm)	Acceptable Qty			A	B	C	$\Phi \leq 0.1$	Ignore			$0.1 < \Phi \leq 0.2$	2			$0.2 < \Phi \leq 0.3$	1			$\Phi > 0.3$	0		
Zone Size (mm)	Acceptable Qty																								
	A	B	C																						
$\Phi \leq 0.1$	Ignore																								
$0.1 < \Phi \leq 0.2$	2																								
$0.2 < \Phi \leq 0.3$	1																								
$\Phi > 0.3$	0																								
	Line defect (LCD /Polarizer black/white line, scratch, stain)	<table border="1"> <thead> <tr> <th>Width(mm)</th> <th>Length(mm)</th> <th>Acceptable Qty</th> </tr> </thead> <tbody> <tr> <td>$\Phi \leq 0.03$</td> <td>Ignore</td> <td>Ignore</td> </tr> <tr> <td>$0.03 < W \leq 0.05$</td> <td>$L \leq 2.0$</td> <td>1</td> </tr> <tr> <td>$0.05 < W$</td> <td colspan="2">0</td> </tr> </tbody> </table>	Width(mm)	Length(mm)	Acceptable Qty	$\Phi \leq 0.03$	Ignore	Ignore	$0.03 < W \leq 0.05$	$L \leq 2.0$	1	$0.05 < W$	0												
Width(mm)	Length(mm)	Acceptable Qty																							
$\Phi \leq 0.03$	Ignore	Ignore																							
$0.03 < W \leq 0.05$	$L \leq 2.0$	1																							
$0.05 < W$	0																								
3.0	Polarizer scratch	<table border="1"> <thead> <tr> <th>Width(mm)</th> <th>Length(mm)</th> <th>Acceptable Qty</th> </tr> </thead> <tbody> <tr> <td>$W \leq 0.03$</td> <td>Ignore</td> <td>Ignore</td> </tr> <tr> <td>$0.03 < W \leq 0.05$</td> <td>$L \leq 2$</td> <td>2</td> </tr> <tr> <td>$0.05 < W \leq 0.10$</td> <td>$L \leq 1$</td> <td>1</td> </tr> <tr> <td colspan="2">$W > 0.10\text{mm}$ or $L > 2\text{mm}$</td> <td>0</td> </tr> </tbody> </table>	Width(mm)	Length(mm)	Acceptable Qty	$W \leq 0.03$	Ignore	Ignore	$0.03 < W \leq 0.05$	$L \leq 2$	2	$0.05 < W \leq 0.10$	$L \leq 1$	1	$W > 0.10\text{mm}$ or $L > 2\text{mm}$		0								
Width(mm)	Length(mm)	Acceptable Qty																							
$W \leq 0.03$	Ignore	Ignore																							
$0.03 < W \leq 0.05$	$L \leq 2$	2																							
$0.05 < W \leq 0.10$	$L \leq 1$	1																							
$W > 0.10\text{mm}$ or $L > 2\text{mm}$		0																							

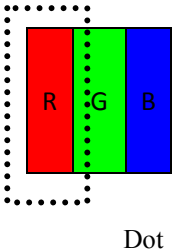

	Polarizer Bubble	<table border="1"> <tr> <td>Zone Size (mm)</td> <td>Acceptable Qty</td> </tr> <tr> <td>$\Phi \leq 0.1$</td> <td>Ignore</td> </tr> <tr> <td>$0.1 < \Phi \leq 0.2$</td> <td>2</td> </tr> <tr> <td>$0.2 < \Phi \leq 0.3$</td> <td>1</td> </tr> <tr> <td></td> <td></td> </tr> </table>	Zone Size (mm)	Acceptable Qty	$\Phi \leq 0.1$	Ignore	$0.1 < \Phi \leq 0.2$	2	$0.2 < \Phi \leq 0.3$	1					
Zone Size (mm)	Acceptable Qty														
$\Phi \leq 0.1$	Ignore														
$0.1 < \Phi \leq 0.2$	2														
$0.2 < \Phi \leq 0.3$	1														
4.0	SMT	According to the <Acceptability of electronic assemblies> IPC-A-610C class 2 standard. Component missing or function defect are Major defect, the others are Minor defect.													
5.0	TFT	<table border="1"> <thead> <tr> <th>distinguish</th> <th>type</th> <th>Acceptable Qty</th> </tr> </thead> <tbody> <tr> <td rowspan="2">Bright dot</td> <td>Any color window</td> <td>0</td> </tr> <tr> <td>Adjacent Bright dot</td> <td>0</td> </tr> <tr> <td rowspan="2">Dark dot</td> <td>Dark dot</td> <td>1</td> </tr> <tr> <td>Adjacent Dark dot</td> <td>0</td> </tr> </tbody> </table> <p>Note: the red (R), green(G), blue (B) 3 points constitute a pixel</p> 	distinguish	type	Acceptable Qty	Bright dot	Any color window	0	Adjacent Bright dot	0	Dark dot	Dark dot	1	Adjacent Dark dot	0
distinguish	type	Acceptable Qty													
Bright dot	Any color window	0													
	Adjacent Bright dot	0													
Dark dot	Dark dot	1													
	Adjacent Dark dot	0													

Criteria (functional items)

Items	Criteria
No display	Not allowed
Display abnormally	Not allowed
Missing vertical, horizontal	Not allowed
Segment	Not allowed
Short circuit	Not allowed
Back-light no lighting,	Not allowed
Flickering and abnormal lighting	Not allowed
Cross-Talk	Not allowed
Noise	Not allowed
Color contrast	Not allowed
The LCD surface dirt	If you cannot use smudgy surface air clean and clear, soco is not acceptable
Components off	Not allowed
FPC&PCB undesirable	Not allowed
Iron frame deformation	Not allowed



10.2 RELIABILITY TEST

ITEM	Condition	Sample size	Criterion
High Temp. Storage	70°C, 240 hrs	5pcs	Inspection after 2~4hours storage at room temperature, the sample shall be free from defects: 1.Air bubble in the LCD; 2.Sealleak; 3.Non-display; 4.Missing segments; 5. The surface shall be free from damage. 6. Contrast must be no more than 10% by the linearity tester. 7. Power must be no more than 10% by the linearity tester.
Low Temp. Storage	-20°C, 240 hrs	5pcs	
High Temp. Operation	60°C,240 hrs	5pcs	
Low Temp. Operation	-10°C, 240 hrs	5pcs	
Humidity operation	40°C,90%RH ,96 hrs	5pcs	
Humidity storage	60°C,90%RH ,96 hrs	5pcs	
Temp humidity cycles	25°C Calefaction/3hrs→60°C/9hrs →Descendtemp/3hrs→25°C/9hrs 90%RH Total:18cycles	5pcs	
Thermal shock	-10°C/30min→60°C/30mins Total:32cycles	5pcs	
Vibration	Amplitude between 5 and 500Hz:3G(30m/s ²)/2hrs for each direction(X,Y,Z)	1Carton-box	
Drop test	0.8m,10times	1Carton-box	
ESD	1.Contact discharge method± 4KV,150pF/330Ω 10times	5pcs	1. After testing, there are no any defective appearances or electrical properties. 2. It can be acceptable when all defective ESD disappears in the RESET.
	2.Air discharge method± 8KV,150pF/330Ω 10times	5pcs	

10.3 Safetv instructions

10.3.1 If the LCD panel breaks, be careful not to get any liquid crystal substance in your mouth.

10.3.2 If the liquid crystal substance touches your skin or clothes, please wash it off immediately by using soap and water.

10.4 Handling Precautions

10.4.1 Avoid static electricity damaging the LSI.

10.4.2 Do not remove the panel or frame from the module .

10.4.3 The polarizing plate of the display is very fragile . So, please handle it very carefully.

10.4.4 Do not wipe the polarizing plate with a dry cloth, as it may easily scratch the surface of the plate.

10.4.5 The color tone of display and background of LCM has the possibility to be changed in the storage temperature range.

10.4.6 Pay attention to the working environment, as the element may be destroyed by static electricity.

--Be sure to ground human body and electric appliance during work.

--Avoid working in a dry environment to minimize the generations of static electricity.

--Static electricity may be generated when the protective film is fast peeled off.

10.4.7 When soldering the terminal of LCM, make certain the AC power source of soldering iron does not leak.



10.4.8 If the display surface becomes contaminated ,breathe on the surface and gently wipe it with a soft-dry- clean cloth .If it is heavily contaminated ,moisten cloth with the following solvent(ex:Ethyl alcohol).Solvents other than those above-mentioned may damage the polarizer(Especially ,do not use them .ex: Warter / Ketone)

10.5 Operation instructions

- 10.5.1 It is recommended to drive the LCD within the specified voltage limits, try to adjust the operating voltage for the optimal contrast, the color and contrast of LCD panel will varies at different temperature.
- 10.5.2 Response time is greatly delayed at low operating temperature range. However, this does not mean the LCD will be out of the order, It will recover when it returns to the specified temperature range.
- 10.5.3 If the display area is pushed hard during operation, the display will become abnormal.
- 10.5.4 Do not operate the LCD at the environments over the specified conditions, this may cause damage on the LCD and shorten the lifetime.

10.6 Storage instructions:

- 10.6.1 Store LCDs in a sealed polyethylene bag.
- 10.6.2 Store LCDs in a dark place, Do not expose to sunlight or fluorescent light. Keep the temperature between 0°C and 35°C.
- 10.6.3 Avoid the polarizer touch any other object, (It is recommended to store them in the container in which they were shipped.)

10.7 Limited Warranty

- 10.7.1 will replace or repair any of its LCD modules, which are found to be defective, when inspected in accordance with LCM acceptance standards (copies available upon request) for a period of 12 months from ink- print date on product
- 10.7.2 Any defects must be returned to within 60 days since ship-out. Confirmation of such date shall be based on freight documents. The warranty liability of wasam limited to repair and/or replacement on defects above (7.1,7.2)
- 10.7.3 No warranty can be granted if the precautions stated above have been disregarded. The typical samples are as below:
 - LCD glass crack/break
 - PCB outlet is damaged or modified.
 - PCB conductors damaged.
 - Circuit modified with by grinding, engraving or painting varnish.
 - FPC crack
- 10.7.4 Modules must be returned with sufficient description of the failures of defects. Any connectors or cable installed by the customer must be removed completely without damaging the PCB outlet, conductors and terminals. Modules must be packed with the container in which they were shipped.





11. Packing method

Please consult our technical department for detail information.